

Hydra-Mate

308930A

Variable Ratio Proportioner

3000 psi (21 MPa, 207 bar) Maximum Working Pressure



Read warnings and instructions.

See page 13-16 for pump model numbers, ratios and working pressures.

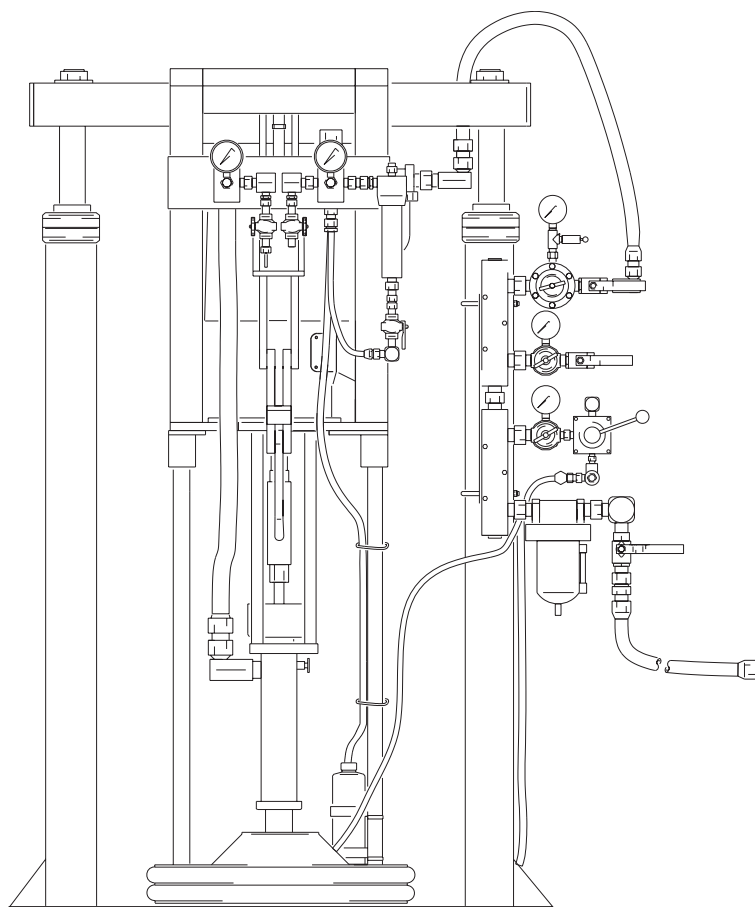

50:1 King Pump Module Shown

9472a

PROVEN QUALITY. LEADING TECHNOLOGY.



Contents

Manual Conventions	2	Air Supply Troubleshooting Chart	30
Warning	3	Pump Troubleshooting Overview	31
Theory of Operation	5	Master Pump Troubleshooting Chart	33
Usage	5	Slave Pump Troubleshooting Chart	34
Major Components	5	Manifold/Mixer Troubleshooting Chart	35
Frame	5	Parts	38
Ratio Proportioning	5	Part No. 953100 & 570312	38
System Components and Operation Overview ..	5	Part No. 954900 & 965580	40
Models	7	Part No. 948094	42
Installation	8	Part No. 902755	43
Typical Installation	8	Part No. 903366	44
Location	8	Part No. 954855	46
Grounding	10	Part No. 948109	48
Flushing	11	Part No. 570293	49
Setup	12	Part No. 570039	50
Setting the Ratio	12	Part No. 947039	51
Output Charts	13	Part No. 570342	52
Before Loading Material	17	Part No. 570381	52
Loading Resin	17	Part No. 570292	53
Priming Resin Pump	18	Part No. 570294	54
Loading Catalyst Material	20	Part No. 570295	55
Priming with Catalyst	22	Part No. 570382	56
Operation	24	Part No. 570383	57
Pressure Relief Procedure	24	Part No. 570384	58
Dispensing Mixed Material	25	Part No. 570184	60
Changing Resin Drum	27	Part No. 570304	62
Changing Catalyst Pail	28	Part No. 570225	64
Filling Catalyst Pressure Tank	28	Part No. 233415	66
Troubleshooting	29	Accessories	66
Hydra-Mate Operating Pressures	29	Technical Data	67
		Graco Warranty	68
		Graco Phone Number	68

Manual Conventions

Warning

 **WARNING**

A warning alerts you to the possibility of serious injury or death if you do not follow the instructions.

Symbols, such as fire and explosion (shown), alert you to a specific hazard and direct you to read the indicated hazard warnings (pages 3-4) for detailed information.

Caution

 **CAUTION**

A caution alerts you to the possibility of damage to or destruction of equipment if you do not follow instructions.

Note

 A note indicates additional helpful information.

WARNING
**INJECTION HAZARD**

Spray from the gun, hose leaks, or ruptured components can inject fluid through skin and cause extremely serious injury, including need for amputation. Fluid splashed in the eyes or on skin can cause serious injury.

- Fluid injected into skin might look like just a cut, but it is a serious injury. **Get immediate medical attention.**
- Do not point the gun at anyone or any part of the body.
- Do not put hand or fingers over the spray tip/nozzle.
- Do not stop or deflect leaks with hand, body, glove or rag.
- Do not “blow back” fluid; this is not an air spray system.
- Always have tip guard and trigger guard on the gun when spraying.
- Check gun diffuser weekly. Refer to gun manual.
- Check trigger safety operation before spraying. Lock trigger safety when you stop spraying.
- Follow the **Pressure Relief Procedure**, page 24, if the spray tip/nozzle clogs and before cleaning, checking or servicing the equipment.
- Tighten fluid connections before operating equipment.
- Check hoses, tubes, and couplings daily. Replace worn or damaged parts immediately. Do not repair high pressure couplings; replace the entire hose.
- Fluid hoses must have spring guards on both ends to help protect them from rupture caused by kinks or bends near the couplings.

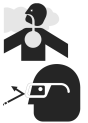
**TOXIC FLUID HAZARD**

Hazardous fluids or toxic fumes can cause serious injury or death if splashed in the eyes or on skin, swallowed, or inhaled.

- Know specific hazards of the fluid. Read fluid manufacturer’s warnings.
- Wear appropriate protective clothing, gloves, eyewear, and respirator.

WARNING
**EQUIPMENT MISUSE HAZARD**

Equipment misuse can cause equipment to rupture, malfunction, or start unexpectedly and cause serious injury.



- This equipment is for professional use only.
- Read manuals, tags, and labels before operating equipment.
- Use equipment only for its intended purpose. If you are uncertain, call your Graco distributor.
- Do not alter or modify equipment. Use only genuine Graco parts and accessories.
- Check equipment daily. Repair or replace worn or damaged parts immediately.
- Do not exceed maximum working pressure of lowest rated system component.
- Use fluids and solvents that are compatible with equipment wetted parts. See **Technical Data** section of all equipment manuals. Read fluid and solvent manufacturer's warnings.
- Route hoses away from traffic areas, sharp edges, moving parts, and hot surfaces. Do not expose Graco hoses to temperatures above 180°F (82°C) or below -40°F (-40°C).
- Comply with all applicable local, state, and national fire, electrical, and other safety regulations.
- Do not use excessive drum separation air pressure as the drum could rupture. Make sure the drum is not damaged and the ram plate is free to exit the drum before applying air pressure.

**FIRE AND EXPLOSION HAZARD**

Improper grounding, poor ventilation, open flames or sparks can cause a hazardous condition and result in fire or explosion and serious injury.

- Ground the equipment and object being sprayed. See **Grounding**, page 10.
- If you experience static sparking or electric shock, **stop operation immediately**. Identify and correct the problem.
- Provide fresh air ventilation to avoid building up flammable fumes.
- Keep the spray area free of debris, including solvent, rags, and gasoline.
- Extinguish all sources of flames in the spray area, including pilot lights and cigarettes.
- Do not turn on or off any light switch or plug or unplug electrical equipment in the spray area while operating or if fumes are present.
- Do not operate a gasoline engine in the spray area.

**MOVING PARTS HAZARD**

Moving parts, such as priming piston and wiper plate, can pinch or amputate fingers. Keep clear of moving parts when starting or operating equipment and when equipment is pressurized.

- Keep hands and fingers away from the priming piston.
- Keep hands away from the ram wiper plate and pail lip.
- Before servicing, follow the **Pressure Relief Procedure**, page 24, to avoid equipment startup.

Theory of Operation

Usage

Hydra-Mate is used with two component materials where one or both components are heavy. This is typically found in the sealant and adhesive industry, where special requirements for loading and pumping necessitate the use of the Hydra-Mate system.

Major Components

The major components of the Hydra-Mate system include the:

- air motor
- resin or master pump
- catalyst or slave pump
- ram
- catalyst feed supply
- mixer manifold or 2K gun
- mixer
- ratio check station
- application device

Frame

The air motor supplies the force and motion required to drive the system. A connecting rod couples the master pump and air motor directly. Air motor force and motion is transmitted through the slave linkage for synchronous motion of the master and slave pumps.

Ratio Proportioning

The master and slave pumps are positive displacement pumps. Positive displacement pumps displace a defined volume of fluid for a given stroke length. The pumps displace equal amounts of material on the up and down strokes but load or prime only on the up stroke.

The master and slave pumps displace different volumes for the same stroke length. By adjusting the slave inlet manifold to different points on the slave linkage, you can change the stroke length of the slave pump, which will change the mix ratio. You can calculate the material mix ratio from the ratio of the pump displacement volume.

Note that the mix ratio of the Hydra-Mate is achieved by volumetric ratio of resin to catalyst and not by weight. These two ratios may be different depending on material properties.

System Components and Operation Overview

Loading the Pumps

The resin and catalyst pumps must completely fill (prime) during the loading stroke, to ensure accurate material displacement.

With high viscosity materials, it is difficult for material to flow into the pump on the loading stroke. A vacuum forms during the piston upstroke, similar to trying to draw thick fluid into a hypodermic syringe. This condition is called *pump cavitation*.

If cavitation occurs, part of the downstroke will be used to fill the vacuum before any material is actually displaced. Since the total stroke length is used to calculate mix ratio, this results in an off-ratio condition.

To prevent cavitation, both pumps are pressure fed. The resin pump is pressurized by a pneumatic ram applying a downward force on a 55 gallon plate fitted into the drum. A shovel action pump fluid inlet further aids in pump priming. Catalyst is delivered to the slave pump by a pressure fed 5 gallon supply module.

Pumping the Fluids to the Mixer

Fluid is pumped through outlet blocks to a mix manifold, where resin and catalyst are first introduced before being mixed in a static mixer.

A check valve injects catalyst into resin at the mix manifold. When enough pressure builds up, the check valve opens and catalyst flows into the mix manifold. This means that during flow conditions with two positive displacement pumps linked together, the pressures at the mix point are equal.

Any pressure differences noted on the gauges while running reflect differences in the pressure lost by each fluid getting from the gauge to the mix point. These pressure drops are caused by hoses and fittings.

Mixing the Fluids

Both components leave the mix manifold and enter a static mixer where they are mixed to a homogeneous blend. The mixer consists of a series of left and right-hand spiral elements.

When the components are pumped through the mixer, they are progressively divided and recombined. Static mixers used on the Hydra-Mate system include the tri-core mixer, flexible hose mixer, or disposable mixer.

Ratio Checks

A ratio check station option verifies the volumetric mix ratio of the two components. It is located at the outlet blocks. With all outbound fluid valves closed, each component flows through individual ball valves opened by a common handle into containers.

Volumetric mix ratio can be calculated from the weight of each component or by direct measurement. Ratio checks are performed with the back pressures set to actual operating pressures to simulate the normal back pressures created by the mix manifold and gun.

Dispense Valve

An *extrusion flow gun* is commonly used as the application device. It has a final or clean up mixer installed in the handle. Various extrusion nozzles are available for caulking or sealing applications.

Some Hydra-Mates use a *2K disposable mixer dispense valve* instead of the flow gun.



The Hydra-Mate can be used in automatic assembly lines with the addition of a logic interface.

Models



Refer to form 684038 for selection information.

Model	Description	
VRHM	Variable Ratio Hydra-Mate	
Code A	Proportioner Pump Modules	Module Number
1	25:1 Bulldog, #7 slave 7.5-16.5:1 Mix	953100
2	25:1 Bulldog, #1 slave 3.7-8.0:1 Mix	570312
3	50:1 Quiet King, #7 slave 7.5-16.5:1 Mix	954900
5	50:1 Quiet King, #5 slave 6.5-13.5:1 Mix, T-Wipers on 55 gal. (208 l) Ram	965580
Code B	Curative Feed Modules	Module Number
1	5:1 Monark on 5 gal. Ram Kit	954855
2	5 gal. Pressure Tank Kit	948109
N	None	
Code C	Boom and/or Hose Kits to Supply Gun Kits (Code D)	Module Number
1	Boom Kit with 10 ft. (3.05 m) hoses to end for silicone or urethane	570293
2	Boom Kit with 10 ft. (3.05 m) hoses to end for polysulfide	570039
3	10 ft. (3.05 m) Hose Extension Kit for silicone or urethane	570342
4	10 ft. (3.05 m) Hose Extension Kit for polysulfide	570381
N	None	
Code D	Mix and Dispense Kits (connects to one of Code C)	Module Number
1	Resin Purge Flexible Mixer polysulfide 10 ft. (3.05 m) hoses	570292
2	Resin Purge Flexible Mixer silicone 10 ft. (3.05 m) hoses	570294
3	Resin Purge Flexible Mixer urethane 10 ft. (3.05 m) hoses	570295
4	Resin Purge Tri-Core Mix polysulfide 10 ft. (3.05 m) hoses	570382
5	Resin Purge Tri-Core Mix silicone 10 ft. (3.05 m) hoses	570383
6	Resin Purge Tri-Core Mix urethane 10 ft. (3.05 m) hoses	570384
7	2K-UL Disposable Mixer polysulfide 10 ft. (3.05 m) hoses	570184
8	2K-UL Disposable Mixer silicone 10 ft. (3.05 m) hoses	570304
9	2K-UL Disposable Mixer urethane 10 ft. (3.05 m) hoses	570225
Code E	Accessories	Module Number
1	Ratio Check Nozzle Kit	233415
N	None	

Installation

Typical Installation

FIG. 1-3 is only a guide for selecting and installing system components and accessories. Contact your Graco distributor for assistance in designing a system to suit your needs.

Key:

A	System Air Shutoff Valve (bleed-type)	L	Catalyst Feed Pressure Gauge
B	Main Air Filter	M	Ratio Check Outlet Valves
C	Ram Directional Valve	N	Catalyst Feed Pump Air Motor Lubricator
D	Ram Air Pressure Regulator	O	Catalyst Strainer (20 mesh)
E	Catalyst Air Supply Valve (bleed-type)	P	Pail Air Blow-off and Return Line Check Valves
F	Catalyst Air supply Regulator	Q	Vent Stick or Valve
G	Main Air Motor Shutoff Valve (bleed-type)	R	Ram Plate with drum vent valve
H	Catalyst Bypass Valve (back to supply)	S	Main Pump Air Regulator
I	Catalyst Outlet Filter	T	Main Pump Bleed Valve
J	Catalyst Outlet Pressure Gauge	U	2K Ultra Lite Gun with disposable mixers
K	Resin Outlet Pressure Gauge	V	Main Motor Lubricator (not visible in FIG. 1)

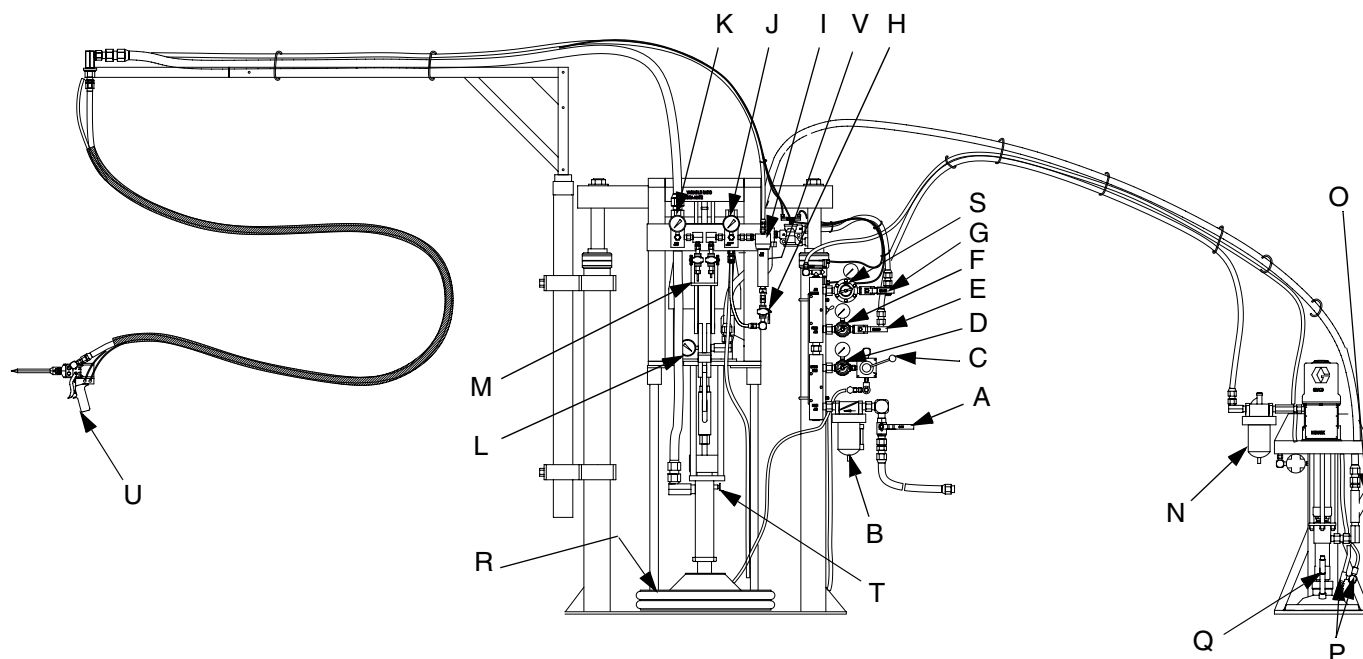

FIG. 1: Installation with Catalyst Pail Pump Feed shown

Location

Position the ram so the air regulators for the pump and ram are easily accessible. Ensure that there is sufficient overhead clearance when the ram is fully raised. Refer to the ram manual for clearance dimensions.

Using the holes in the ram base as a guide, drill four holes for 1/2 in. (13 mm) anchors.

Check that the ram base is level in all directions. If necessary, level the base using metal shims. Secure the base to the floor using 1/2 in. (13 mm) anchors which are long enough to prevent the ram from tipping.

Key:

- W Air Line, Pressure Pot; 1/4" ID
- X Fluid Return Line; 1/4" npsm (fbe) x 10' (3.05 m)
- Y Fluid Supply Line; 3/8" npt (mbe) x 10' (3.05 m)
- Z Pressure Pot

- AA Fluid Supply Line; 1/2 npt (mbe) x 10' (3.05 m)
- AB Air Line, Ram; 1/4" ID x 10' (3.05 m)
- AC Air Line, Pump; 1/2" ID x 10' (3.05 m)
- AD Air Line, Main; 3/4 npt (mbe) x 10' (3.05 m)

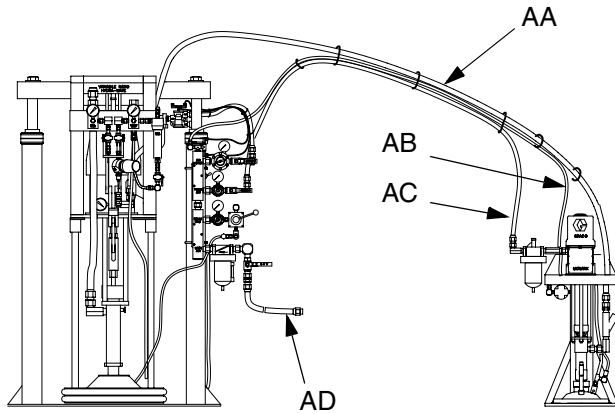

Catalyst Pail Pump Feed - see page 46

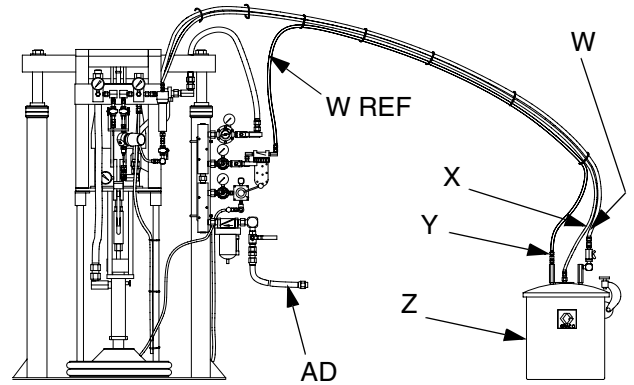

Catalyst Pressure Tank Feed - see page 48

FIG. 2

Key:

- AE Mix and Gun Kit; resin purge with Tri-Core Mixer
- AF Mix and Gun Kit; resin purge with Flexible Mixer
- AG Catalyst Shutoff Valve
- AH Catalyst Injector Valve

- AI Tri-Core Mixer
- AJ Flexible Mixer
- AK Gun Handle Static Mixer (inside)
- AL Gun Hose Swivel

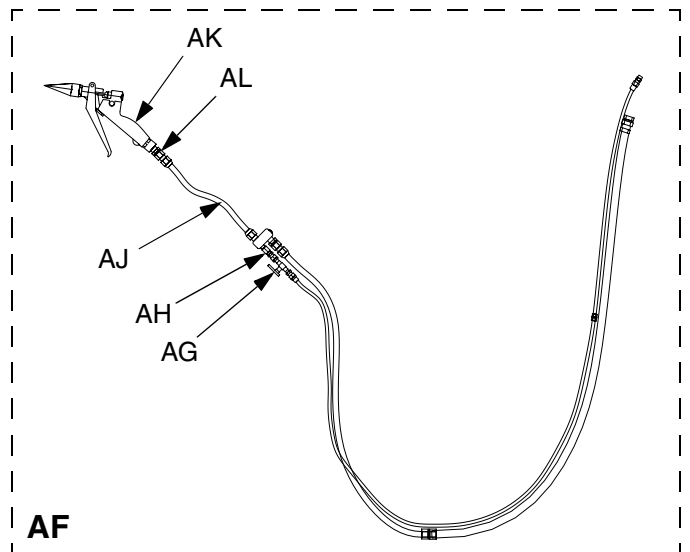
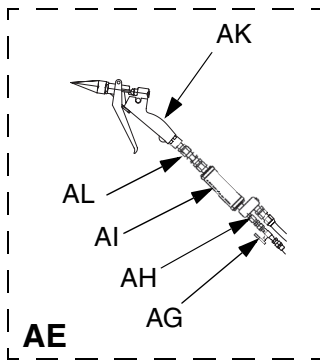



FIG. 3

Grounding

WARNING



The system must be properly grounded. Read warnings, page 4. Follow the instructions below.

Pump: use the ground wire and clamp (supplied). There are two styles of grounding connections on pump air motors.

If you have the ground screw (Z) shown in FIG. 4 (King air motor only), you need to order part no. 222011 ground wire, ring terminal, and clamp assembly (Y). To install 222011, remove the ground screw (Z) and insert it through the eye of ring terminal (X), then tighten ground screw back into air motor as shown in FIG. 4. Connect the other end of the wire to a true earth ground.

If you have the ground screw (Z) shown in FIG. 5, loosen the grounding lug locknut (W) and washer (X). Insert one end of the ground wire (Y) into the slot in lug (Z) and tighten the locknut securely. Connect the other end of the wire to a true earth ground. Order 237569 ground wire and clamp assembly.

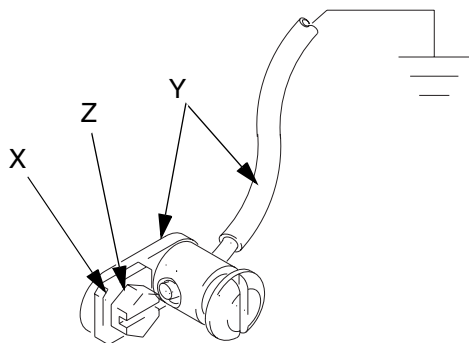

FIG. 4: Ground Screw (King air motor only)

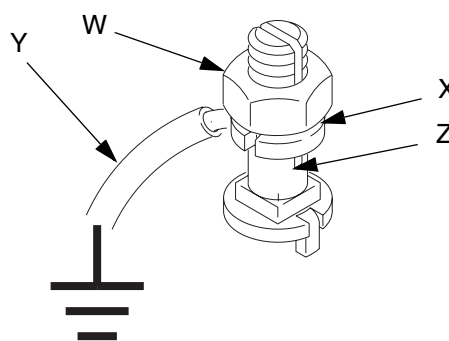

FIG. 5 Ground Screw

Air and fluid hoses: use only electrically conductive hoses with a maximum of 500 ft. (150 m) combined hose length to ensure grounding continuity. Check the electrical resistance of your air and fluid hoses. If the total resistance to ground exceeds 29 megohms, replace the hose immediately.

Air compressor: follow manufacturer's recommendations.

Spray gun/dispense valve: ground through connection to a properly grounded fluid hose and pump.





Fluid supply container: follow your local code.

Substrate: follow your local code.

Solvent pails used when flushing: follow your local code. Use only conductive, metal pails, placed on a grounded surface. Do not place the pail on a nonconductive surface, such as paper or cardboard, which interrupts grounding continuity.

To maintain grounding continuity when flushing or relieving pressure: hold a metal part of the gun/dispense valve firmly to the side of a grounded metal pail, then trigger the gun/valve.

Flushing

 WARNING
  
<p>Read warnings, pages 3-4. Follow Grounding instructions, page 10.</p>

- The equipment was tested with light, soluble oil. Flush the system before loading material to avoid contamination.
- Flush at the lowest pressure possible and check connectors for leaks.

To flush the system:

1. You must remove the drum ram plate to immerse the resin pump in a solvent pail. To remove the plate:
 - a. Disconnect the blow-off air line from the ram plate.
 - b. Disconnect the tie rod nuts from the ram cross beam.
 - c. Remove seal plates between the pump and ram.
 - d. If a pail ram is used with the catalyst supply, remove the pail plate by loosening the 2 set screws.

- e. Position the solvent pail so the pump inlet is in the solvent.



Use solvent that is compatible with the equipment wetted parts and the material you will dispense.

- f. Support the ram(s) so that the pump inlet and piston will not hit the base plate or pail bottom.
- g. Make sure both resin and catalyst outlet hoses are open.

2. Flush the system and all hoses by very slowly opening the motor control valves until 30 psi (207 kPa, 21 bar) is shown on the resin outlet pressure gauge.

Flush for 1-2 minutes, then close the motor control valves.

 CAUTION
<p>To avoid damaging the pump, open the motor control valves very slowly to prevent a pump runaway condition.</p>

To avoid damaging the pump, open the motor control valves very slowly to prevent a pump runaway condition.



It is normal for the air valve to exhaust air when it is partially open.

3. Check connectors for leaks and tighten them if necessary.
4. Remove the solvent pail(s) from the pump inlets.
5. Operate the pump(s) at low pressure to remove excess solvent.
6. Reinstall the drum or pail ram plates.

Setup

WARNING



Read warnings, pages 3-4, before operating equipment.

Setting the Ratio

Volume Adjustment

To adjust the volume of material displaced by the slave pump (AA), loosen the clamping bolts (BB) on the adjuster at the bottom of the frame. See FIG. 7. Slide the adjuster along the setpoint scale (CC). Move adjuster toward the master pump to increase volume (closer ratio) and away from the master pump to decrease volume (wider ratio). See FIG. 6. Refer to the scale on the pivot arm. It may be necessary to jog the air motor with the air control ball valve to reposition the adjuster. When adjuster is in desired position, tighten the bolts (BB).

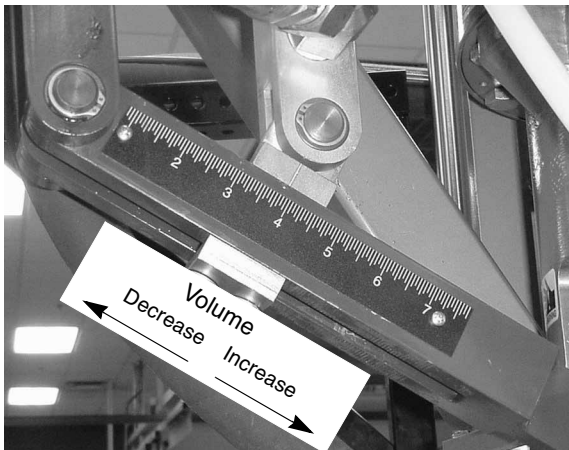

FIG. 6

Scale Setting

Refer to the Hydra-Mate Output Charts on the following pages to set the scale. Make final adjustments after the material is loaded. See manual 309207 for detailed ratio check instructions.

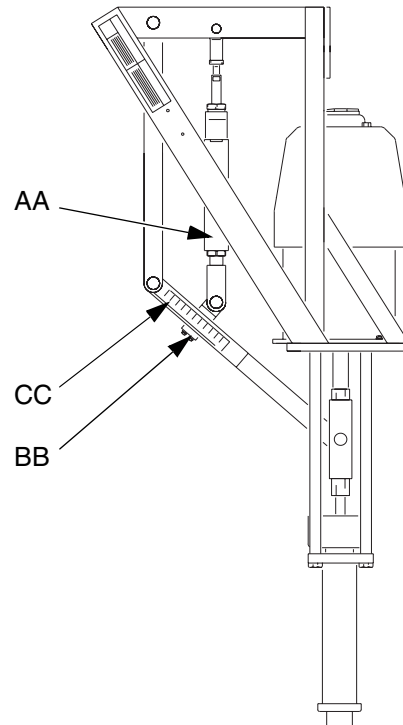

FIG. 7

Output Charts

Hydra-Mate Module 953100

Mix Ratio By Volume	Scale Setting	Slave Stroke	Fluid/Air Pressure Ratio	Output Per Cycle cc's
7.40	6.32	2.20	25.90	111.99
7.75	6.00	2.10	26.04	111.38
8.14	5.70	2.00	26.18	110.78
8.57	5.41	1.90	26.33	110.17
9.04	5.13	1.80	26.47	109.56
9.57	4.85	1.70	26.62	108.96
10.17	4.57	1.60	26.77	108.35
10.85	4.29	1.50	26.92	107.74
11.62	4.02	1.40	27.07	107.14
12.52	3.76	1.30	27.23	106.53
13.56	3.50	1.20	27.38	105.93
14.79	3.25	1.10	27.54	105.32
16.27	3.00	1.00	27.70	104.71

	Type	Number	Area in Sq. In.
Master Pump	25:1	222639	1.31
Slave Pump	#7	222017	0.37
Motor	Bulldog	902098	38.48

Ratio Adjustment Chart

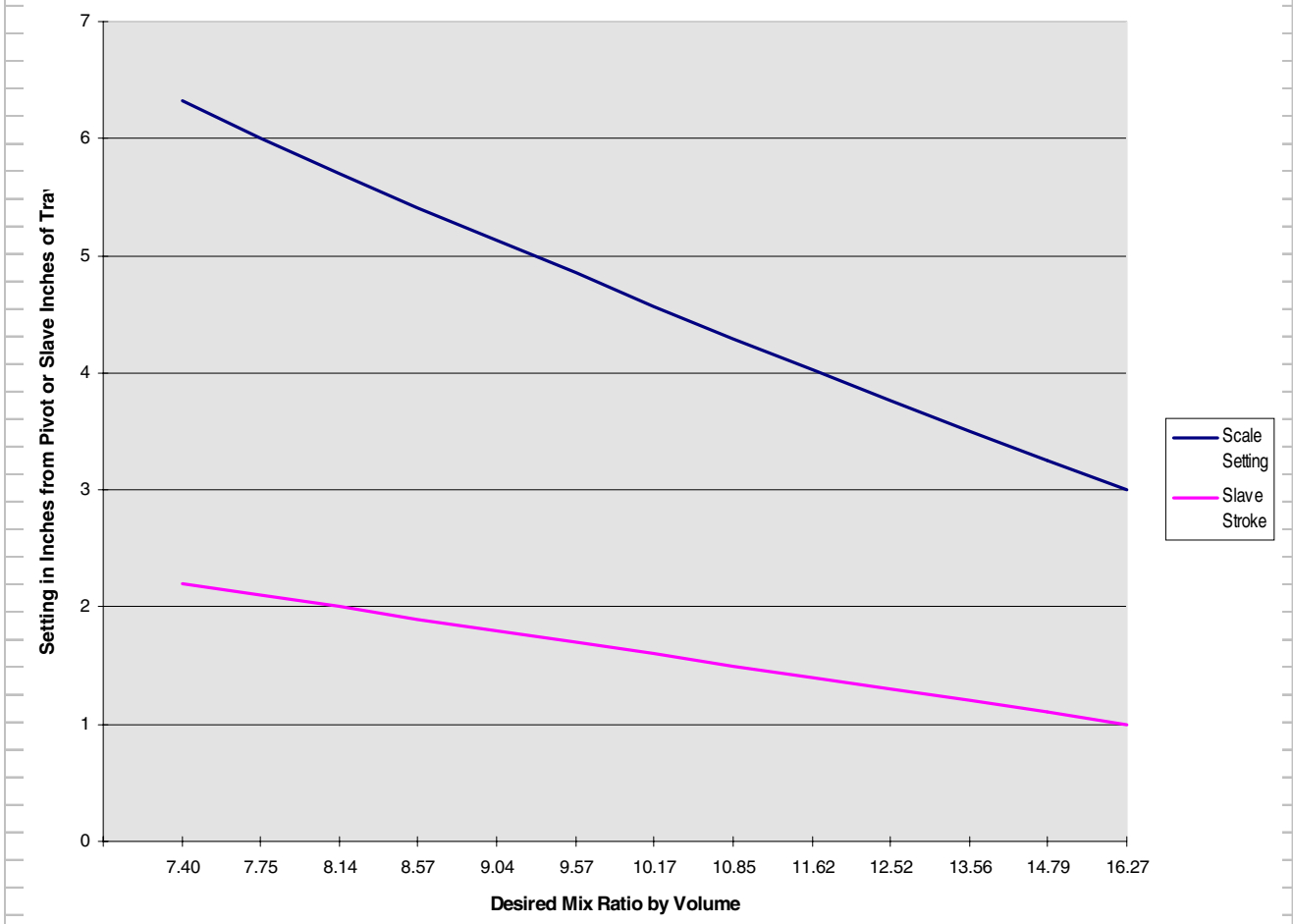

Hydra-Mate Module 570312

Mix Ratio By Volume	Scale Setting	Slave Stroke	Fluid/Air Pressure Ratio	Output Per Cycle cc's
3.70	6.32	2.20	23.14	125.33
3.87	6.00	2.10	23.37	124.12
4.07	5.70	2.00	23.60	122.90
4.28	5.41	1.90	23.84	121.69
4.52	5.13	1.80	24.08	120.48
4.79	4.85	1.70	24.32	119.26
5.09	4.57	1.60	24.57	118.05
5.42	4.29	1.50	24.82	116.84
5.81	4.02	1.40	25.09	115.63
6.26	3.76	1.30	25.35	114.41
6.78	3.50	1.20	25.62	113.20
7.40	3.25	1.10	25.90	111.99
8.14	3.00	1.00	26.18	110.78

	Type	Number	Area in Sq. In.
Master Pump	25:1	222639	1.31
Slave Pump	#1	948641	0.74
Motor	Bulldog	902098	38.48

Ratio Adjustment Chart

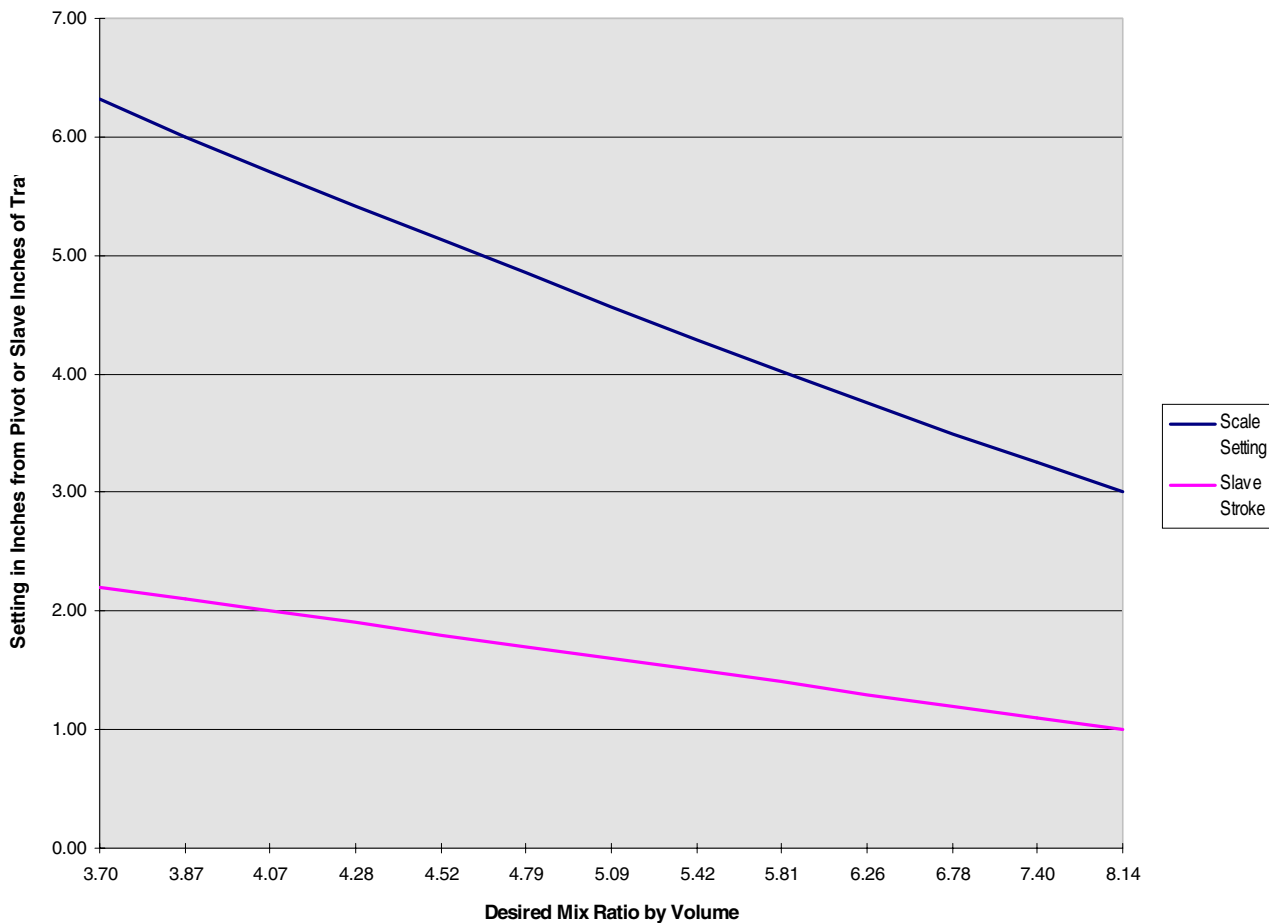

Hydra-Mate Module 954900

Mix Ratio By Volume	Scale Setting	Slave Stroke	Fluid/Air Pressure Ratio	Output Per Cycle cc's
7.40	6.32	2.20	52.97	111.99
7.75	6.00	2.10	53.26	111.38
8.14	5.70	2.00	53.55	110.78
8.57	5.41	1.90	53.85	110.17
9.04	5.13	1.80	54.14	109.56
9.57	4.85	1.70	54.44	108.96
10.17	4.57	1.60	54.75	108.35
10.85	4.29	1.50	55.06	107.74
11.62	4.02	1.40	55.37	107.14
12.52	3.76	1.30	55.68	106.53
13.56	3.50	1.20	56.00	105.93
14.79	3.25	1.10	56.32	105.32
16.27	3.00	1.00	56.65	104.71

	Type	Number	Area in Sq. In.
Master Pump	50:1	222639	1.31
Slave Pump	#7	222017	0.37
Motor	Quiet King	220106	78.53

Ratio Adjustment Chart

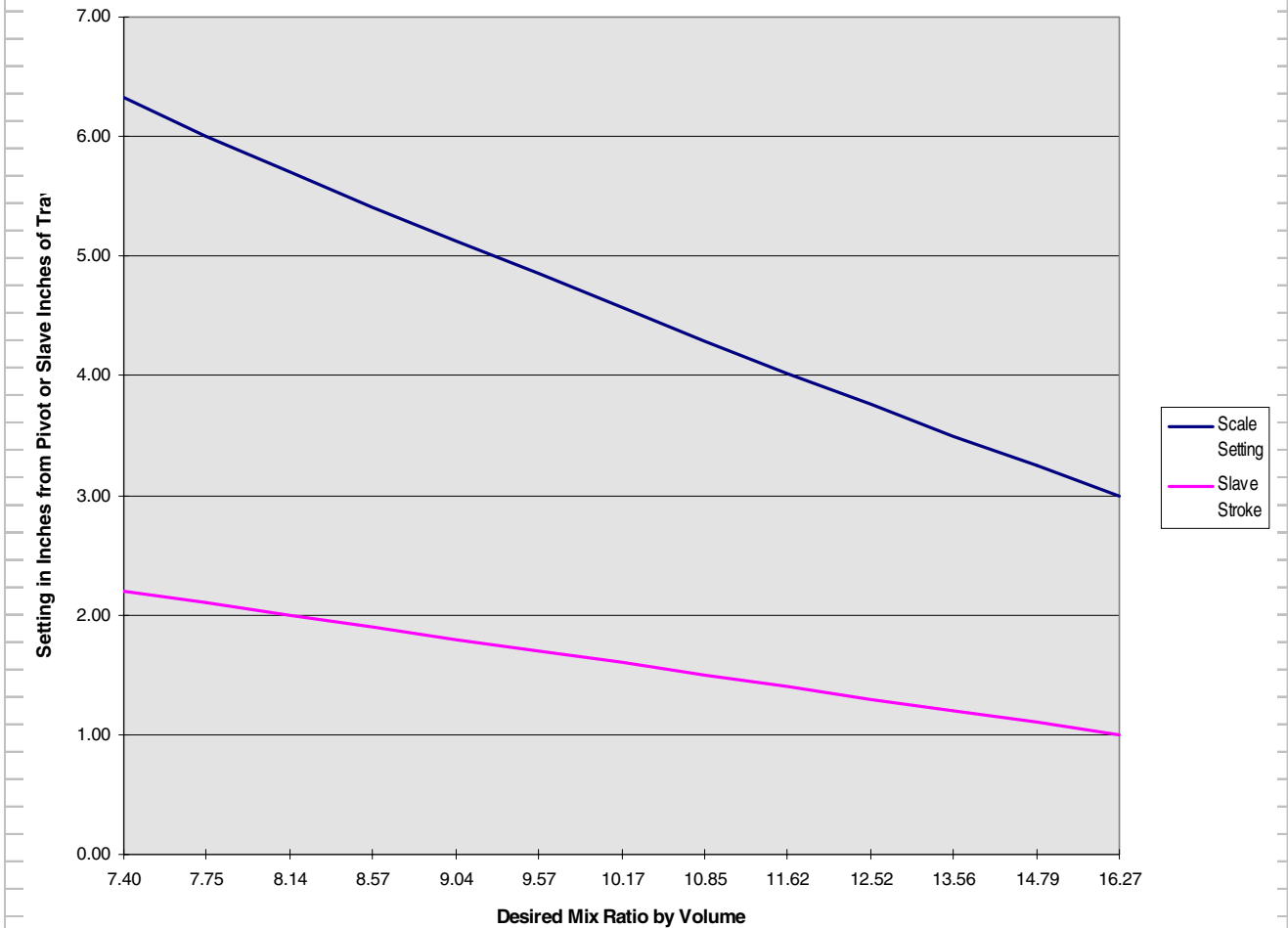

Hydra-Mate Module 965580

Mix Ratio By Volume	Scale Setting	Slave Stroke	Fluid/Air Pressure Ratio	Output Per Cycle cc's
6.16	6.32	2.20	51.74	114.66
6.46	6.00	2.10	52.07	113.93
6.78	5.70	2.00	52.40	113.20
7.14	5.41	1.90	52.74	112.47
7.53	5.13	1.80	53.09	111.75
7.98	4.85	1.70	53.43	111.02
8.48	4.57	1.60	53.79	110.29
9.04	4.29	1.50	54.14	109.56
9.69	4.02	1.40	54.50	108.84
10.43	3.76	1.30	54.87	108.11
11.30	3.50	1.20	55.24	107.38
12.33	3.25	1.10	55.62	106.65
13.56	3.00	1.00	56.00	105.93

	Type	Number	Area in Sq. In.
Master Pump	50:1	222639	1.31
Slave Pump	#5	222015	0.44
Motor	Quiet King	220106	78.53

Ratio Adjustment Chart

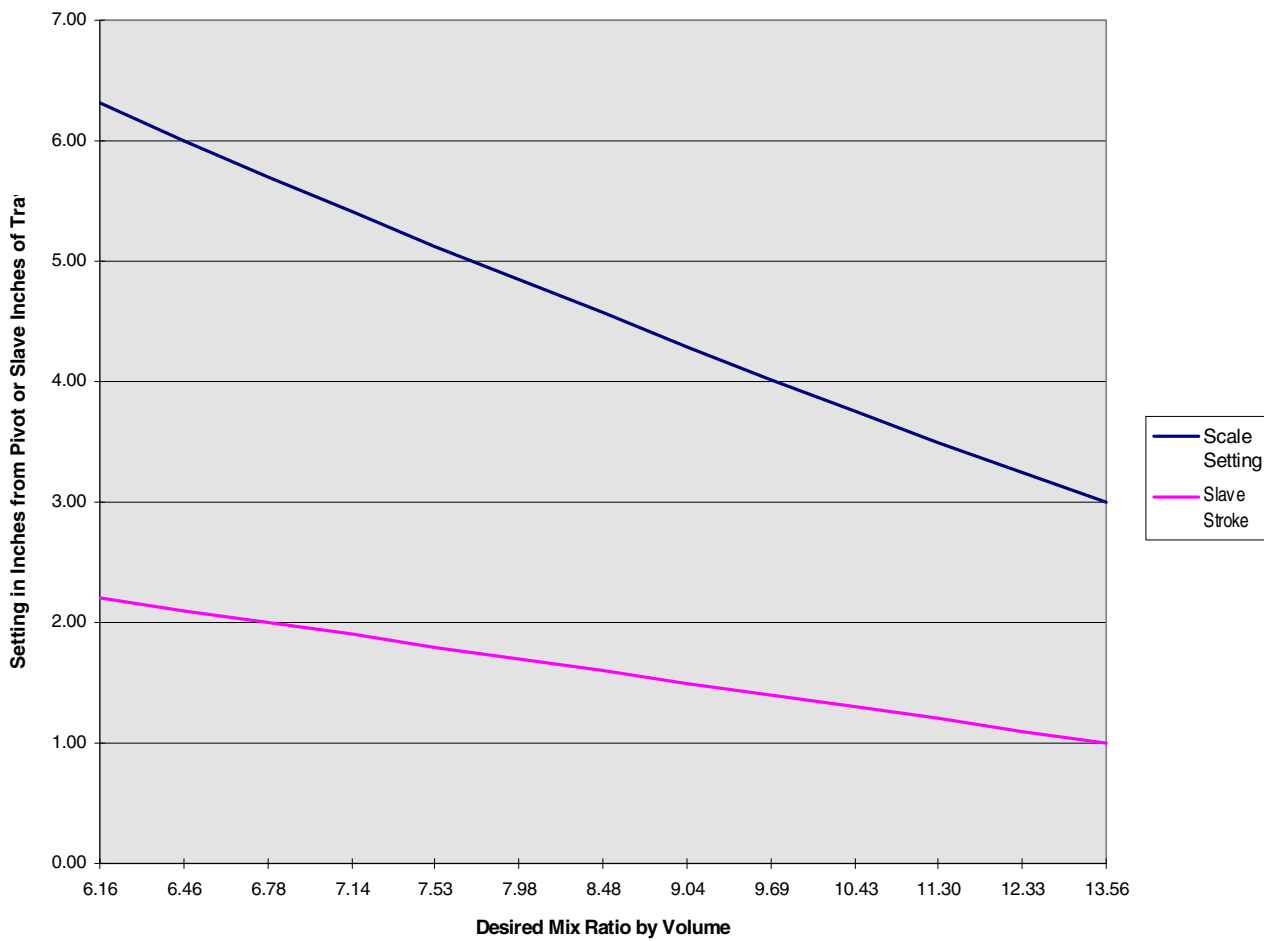

Before Loading Material

1. Check fluid and air lines and tighten if necessary.
2. Make sure there is a minimum overhead clearance of 110 in. (2.79 m).
3. Fill air line lubricators for the pump motor(s) with SAE 10 W non-detergent oil (not included).
4. Fill resin pump and catalyst feed pump wet cups (DD) 2/3 full with Graco T.S.L. fluid (throat seal lubricant), FIG. 8.



- If a catalyst feed tank contains urethanes, fill the slave pump wet cup with ISO pump oil 217374 (included). Mount desiccant air dryer on the catalyst tank air supply outlet on the proportioner. See page 48.
- ISO pump oil is used with moisture sensitive catalysts.

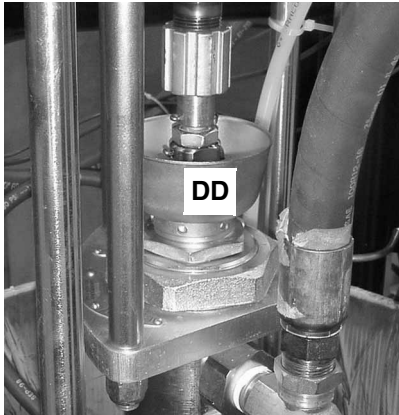

FIG. 8

5. Close (turn fully counterclockwise) all air regulators.
6. Connect the 3/4 in. (19 mm) ID x 10 ft. (3.05 m) air hose (provided) to your air supply.



- Do not use a restrictive quick-disconnect. The air supply pressure must be consistently above the pressure you set on the main air motor regulator.

Loading Resin

1. Make sure all air regulators are fully closed.
2. Open the main air supply shutoff valve (A), FIG. 9.

3. Place the ram lever (C) in the UP position.

CAUTION

As the ram rises, make sure hoses do not catch on any components. If a hose catches, immediately stop the ram (move lever to NEUTRAL position) and correct the problem. Lower the ram if necessary to redirect hoses.

4. Slowly turn the ram air regulator (D) clockwise until the ram begins rising.

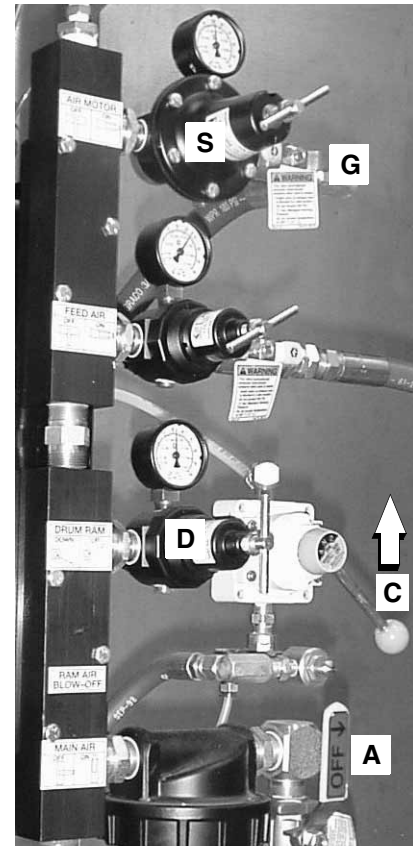

FIG. 9

5. Apply a thin coating of lubricant to the ram plate drum seals.
6. Open the material container. Remove any packing materials, and inspect for material contamination. If the container has a plastic liner, pull it tightly over the sides of the container, and secure the liner in place with tape wrapped below the top drum rim.
7. Position the drum so it rests evenly between the centering guides and is fully backed into the stops located near the back of the ram base plate.

8. Open the drum vent valve (R), FIG. 10.

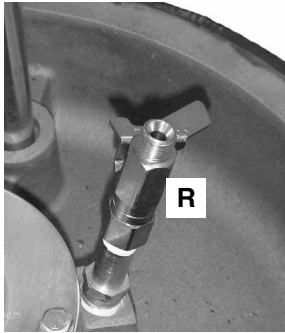

FIG. 10

WARNING



When lowering the ram, keep hands and body away from the ram plate and material drum. Read warnings, page 4.

9. Lower the ram plate into the drum (move ram lever to DOWN), FIG. 11.

CAUTION

Do not lower ram without a drum in place. Doing so can damage drum centering guides.

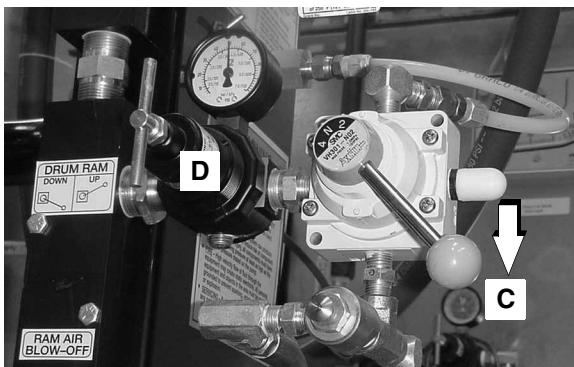

FIG. 11

10. After the ram plate seals contact the drum, adjust the ram air regulator (D) to about 30-50 psi (207-345 kPa, 2.1-3.4 bar).
11. When the ram stops and material fills the bleed port (or air stops bleeding out), close the drum vent valve (R), FIG. 10.

Priming Resin Pump



If you have a disposable mixer gun, switch the air toggle switch (on air control kit) to BYPASS.

1. Place a waste container under the pump bleed valve (T), located behind the displacement pump outlet, FIG. 12. Using an adjustable wrench, open the bleed valve counterclockwise 1/3-1/2 turn.

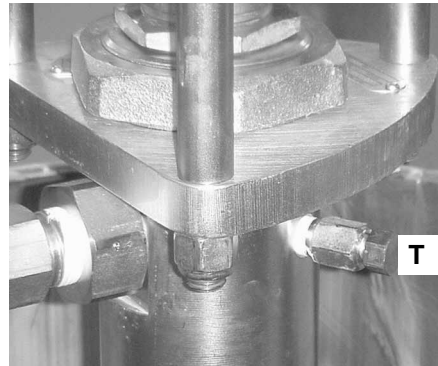

FIG. 12

2. Slowly open the main air motor shutoff valve (G), FIG. 9. Make sure the pump begins to cycle and material flows from the bleed valve (T) after several cycles of the pump, FIG. 12.



If the pump does not cycle, close the air shutoff valve (G), adjust the air motor regulator (S) up 5 psi (34 kPa, 0.3 bar) and repeat step 2, FIG. 9. Never adjust the regulator by more than 5 psi (34 kPa, 0.3 bar) increments, FIG. 13.

3. Operate the pump until it moves smoothly in both directions with no air popping or erratic movement, then close the air motor shutoff valve (G), FIG. 9.
4. Close the bleed valve (T), FIG. 12.

5. Make sure the air motor and catalyst feed air shutoff valves (G and E) are closed, FIG. 13.

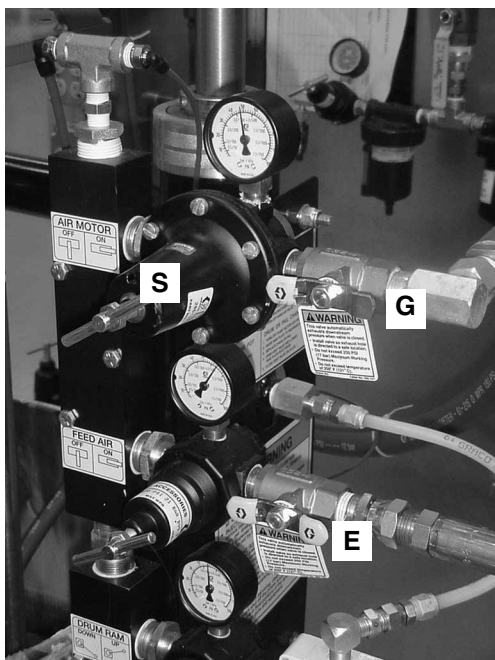

FIG. 13

6. Adjust the pump air regulator (S) to approximately 10-15 psi (69-103 kPa, 0.7-1 bar).
7. Place the gun/resin hose over a waste container.
8. Open the catalyst bypass valve (H), FIG. 15.

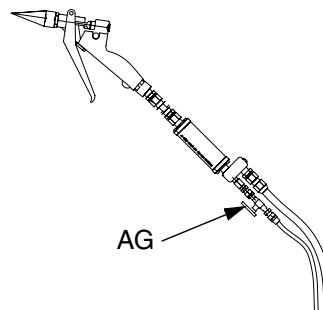

FIG. 14



FIG. 15

9. Open the air motor shutoff valve (G) and continue pumping until clean material, with no air pockets, dispenses from the resin hose into the waste container, then close the shutoff valve, FIG. 13.

CAUTION

Do not operate the pump with both the catalyst shutoff valve (AG, FIG. 14) and the catalyst bypass valve (H, FIG. 15) in the closed position. Doing so will cause excessive pressure to develop in catalyst lines and the safety relief valve to open. Make sure the catalyst relief valve is operational and free from blockage at all times. See valve manual 308547.

Loading Catalyst Material

Follow the procedure for the type of supply equipment being used.

Pneumatic Pail Ram and Piston Pump

1. Close all air regulators and air valves.
2. Set the pail ram air regulator (EE) to 40 psi (0.28 MPa, 2.8 bar), FIG. 16.
3. Push the ram directional lever (FF) to the UP position and let the ram rise to its full height.
4. Remove the catalyst pail cover. If the material has separated, carefully stir it with a metal or plastic rod until it is mixed. Do not use wood to stir as it can splinter and contaminate the material. Do not mix air into the material.
5. Set the pail on the ram base. Slide it back toward the ram tube and supports and center it under the wiper plate (RR). To prevent air from being trapped

under the wiper plate, scoop fluid from the center of the pail to the sides to make the surface concave.

⚠ WARNING



When operating the pump or raising or lowering the ram, keep hands away from the wiper plate, fluid container lip, and pump intake. Read warnings, page 4.

6. With hands away from the pail and wiper plate (RR), set the ram lever (FF) to NEUTRAL (horizontal position). Let the ram lower until the wiper plate rests on the pail lip.
7. Ensure the pail is aligned with the wiper plate, and open the vent ball valve (Q) to allow air to escape.
8. Push the ram directional lever (FF) DOWN and continue to lower the ram until fluid appears at the wiper plate vent hole. Close the pail vent ball valve (Q).

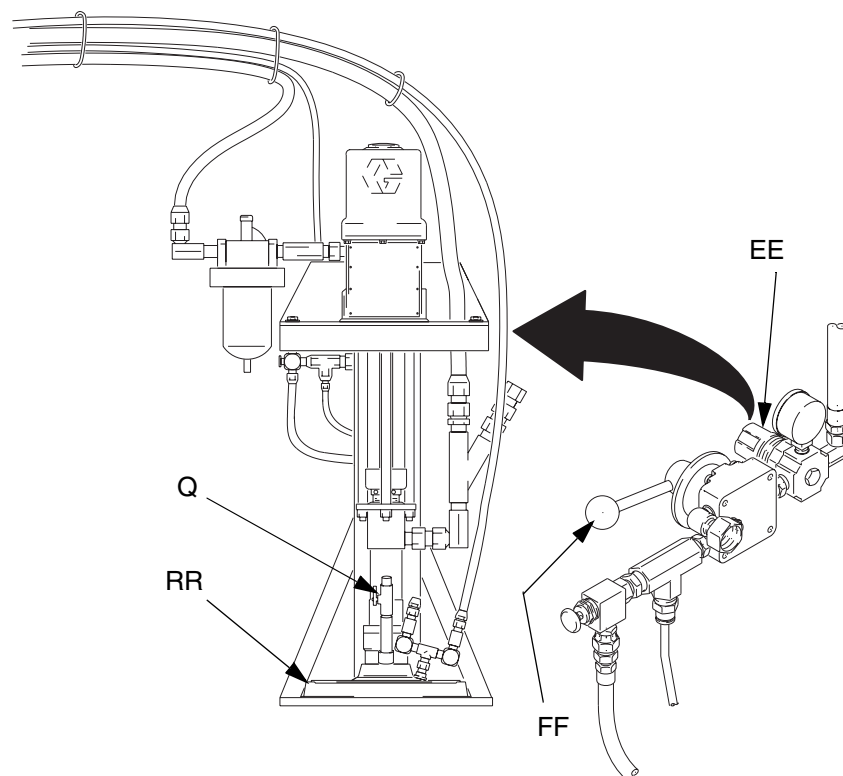

FIG. 16

Pressure Tank

1. Remove the pressure tank lid and any items shipped inside the tank. Make sure the tank is clean, or use the liner supplied.
2. Be sure the desiccant air dryer is mounted on the catalyst tank air supply of the proportioner air control module. See page 48.
3. Gently roll an unopened pail of catalyst on the floor for several revolutions to mix it.
4. Open the pail outlet and carefully pour the catalyst into the tank.
5. Immediately close the tank by tightening the T-handles (GG) evenly, FIG. 17.

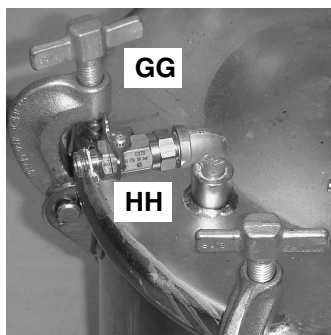

FIG. 17

6. Pressurize the tank with dried air by opening the catalyst air shutoff valve (E) and the pressure tank air shutoff valve (HH), FIG. 17-18.

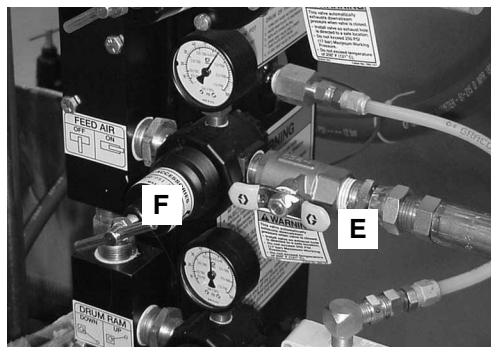

FIG. 18

7. Set the catalyst air regulator (F) to 40 psi (276 kPa, 2.8 bar).

Priming with Catalyst

1. Make sure the air motor and catalyst feed air shutoff valves (G and E) are closed, FIG. 19.

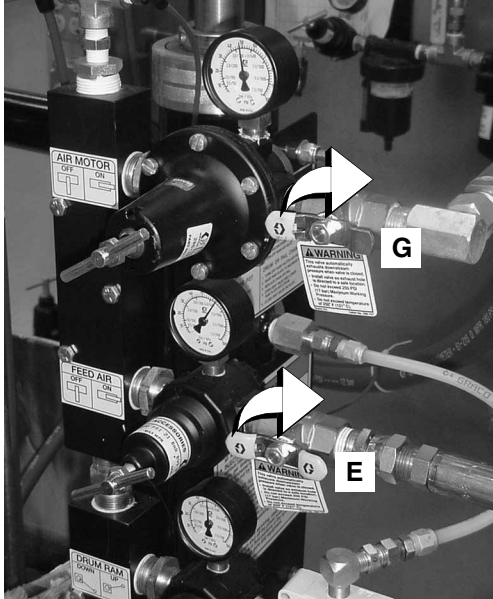

FIG. 19

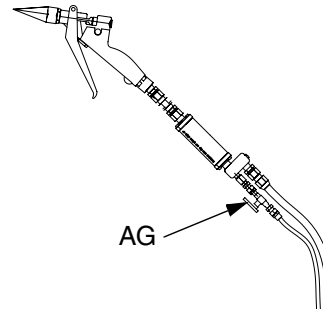

FIG. 20

Resin Purge Models

Follow steps 2-4. 2K UltraLite Disposable Mixer Gun models, go to step 5.

2. Fill the hose to the manifold. Disconnect the catalyst hose [with the shutoff valve (AG)] from the mix manifold, and place the hose over a waste container, FIG. 20.

CAUTION

Do not operate the pump with both the catalyst shutoff valve (AG) and the catalyst bypass valve (H) in the closed position. FIG. 20-21. Doing so will cause excessive pressure to develop in catalyst lines and the safety relief valve to open. Make sure the catalyst relief valve is operational and free from blockage at all times. See valve manual 308547.

3. Open the catalyst hose shutoff valve (AG), then slowly crack open the feed air shutoff valve (E) until a smooth, air free flow of catalyst is dispensed.

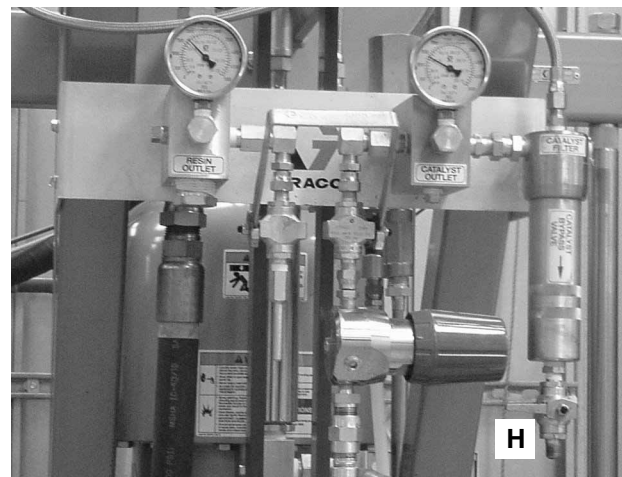

FIG. 21

4. Close the feed air shutoff valve (E) and reconnect the catalyst hose to the mix manifold, FIG. 19. Continue with step 8.

2K UltraLite Disposable Mixer Gun Models

Follow steps 5-10.

5. Fill the hose to the gun. Trigger the gun into a waste container.
6. Open the catalyst feed air shutoff valve (E). Catalyst will feed through the metering cylinder to the mix gun.
7. When bubble free material is dispensed, stop triggering the gun.

All Models

8. Fill the catalyst bypass hose. Disconnect the catalyst return hose from the ram plate or pressure tank return fitting.
9. Open the catalyst bypass valve (H), close catalyst shutoff valve (AG), then slowly crack open the feed air shutoff valve (E) until a smooth, air free flow of catalyst is dispensed.
10. Close the catalyst bypass valve (H) and reconnect the catalyst return hose to the ram plate or pressure tank.



The system is now ready to dispense mixed material.



**CAUTION**

The materials will cure after mixing. Purge the mixer, hose, and gun with clean material before the material begins to cure.

Operation

Pressure Relief Procedure

WARNING

Read warnings, page 3, and follow the **Pressure Relief Procedure** whenever you:

- are instructed to relieve pressure
- stop dispensing
- check or service any of the equipment
- install or clean the nozzle.

1. Purge mixed material if necessary. See page 26.
2. Close the main air shutoff valve (A), FIG. 22.

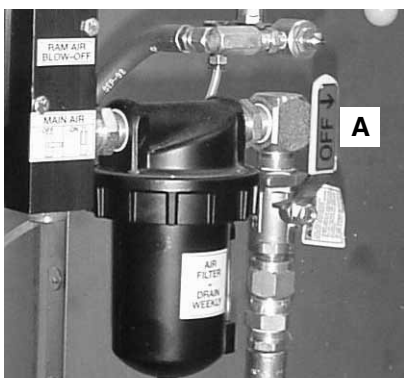

FIG. 22

3. If a catalyst pressure tank is used, open its vent (refer to page 48).
4. Hold a metal part of the gun firmly to the side of a grounded metal pail, and trigger the gun to relieve pressure.

5. Open the catalyst bypass valve (H) and the resin pump bleeder valve (T), having a container ready to catch the drainage, FIG. 23-24.

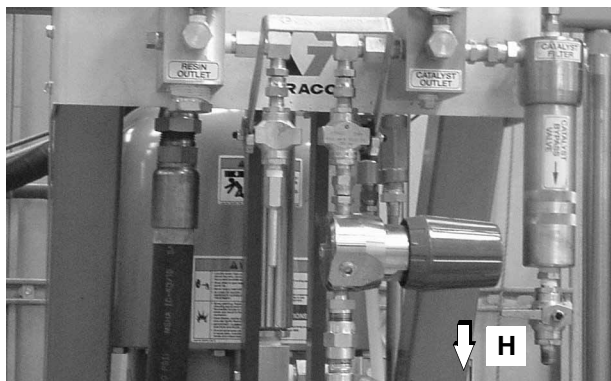

FIG. 23

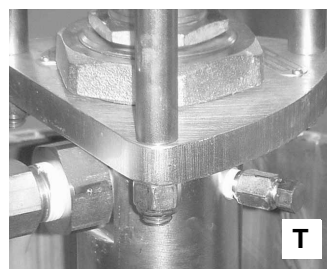

FIG. 24

6. Leave the bypass valve (H) open until you are ready to dispense again.
7. *If you suspect that the nozzle or hose is completely clogged, or that pressure has not been fully relieved after following the steps above, very slowly loosen the tip retaining nut or hose end coupling and relieve pressure gradually, then loosen it completely, and clear the nozzle or hose.*

Dispensing Mixed Material

⚠ CAUTION

Make sure the catalyst relief valve is operational and free from blockage at all times. See manual 308547. If the relief valve fails, the overpressure rupture disc opens and catalyst is diverted to a waste container mounted on the ram base plate.

Hydra-Mate with Resin Purge Gun Kit

1. Load the material. See page 17.
2. Set ratio. See page 12.
3. Open the air motor and catalyst air shutoff valves (G and E), FIG. 25. Make sure the catalyst bypass valve is closed (H), FIG. 26.

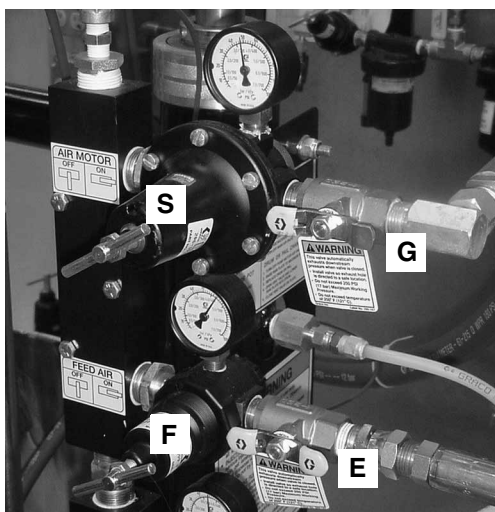

FIG. 25

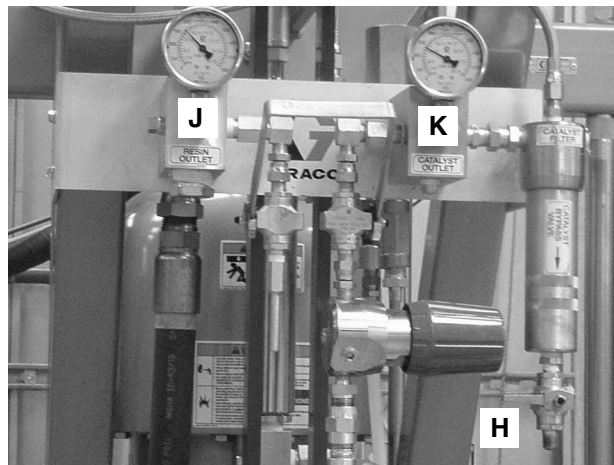

FIG. 26

4. Adjust the air motor air regulator (S) until resin and catalyst outbound gauges (J and K) show the desired pressure, FIG. 25-26.
5. Trigger the gun to dispense mixed material.
6. Adjust the catalyst supply air regulator (F) so that catalyst inbound fluid pressure is no more than 1/4 of catalyst outbound fluid pressure.
7. Adjust the air motor air regulator (S) for the desired flow rate.

Resin Purging Mixed Material

⚠ CAUTION

Do not operate the pump with both the catalyst feed shutoff valve (AG) and the catalyst bypass valve (H) in the closed position. Doing so will cause excessive pressure to develop in catalyst lines and the safety relief valve to open. Make sure the catalyst relief valve is operational and free from blockage at all times. See valve manual 308547.

1. Open the catalyst bypass valve (H), FIG. 26.
2. Close the catalyst shutoff valve (AG), FIG. 27.

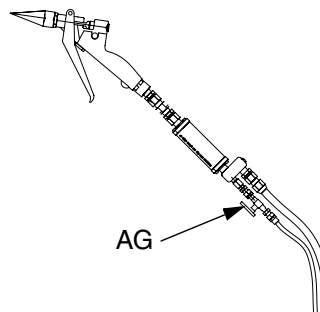

FIG. 27

3. Dispense material from the gun until no catalyst is present.



To resume dispensing mixed material, open catalyst shutoff valve (AG), close catalyst bypass valve (H), and trigger gun until mixed material dispenses.

Hydra-Mate with Disposable Mixer Gun

1. Load the material. See page 17.
2. Set ratio. See page 12.
3. Install the mixer on the gun.
4. Open the air motor and catalyst air shutoff valves (G and E), FIG. 28. Make sure the catalyst bypass valve (H) is closed, FIG. 26, and the motor air pilot bypass valve is switched to NORMAL.

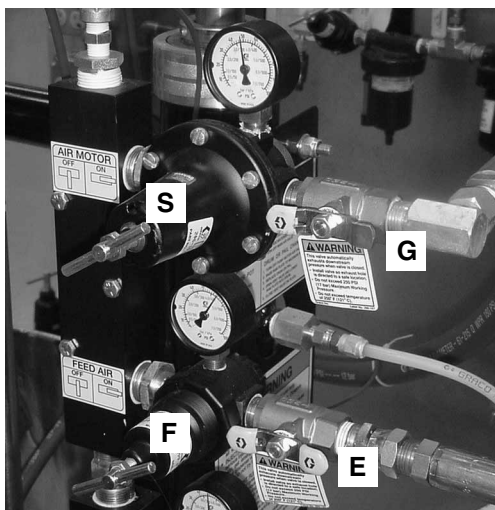

FIG. 28

5. Trigger the finger switch to dispense mixed material.
6. Adjust the catalyst supply air regulator (F) so that catalyst inbound pressure is no more than 1/4 of catalyst outbound pressure, FIG. 28.
7. Adjust the air motor air regulator (S) for the desired flow rate.
8. After you are done dispensing, remove and dispose of the mixer, and install a red plastic cap (part no. 551327).

Changing Resin Drum

When the ram plate is extended fully to the bottom of the drum and the pump begins to cavitate, you need to change the drum. It is recommended that you check and refill the catalyst material at the same time.

1. Close the air motor shutoff valve (G), FIG. 28.
2. With the ram lever (C) in the neutral position, adjust the ram regulator (D) to 0 psi.
3. Place the ram lever (C) in the UP position, FIG. 29.

⚠ WARNING



Do not use excessive drum separation air pressure. Make sure the drum is not damaged and the ram plate is free to exit the drum. Read warnings, page 4.

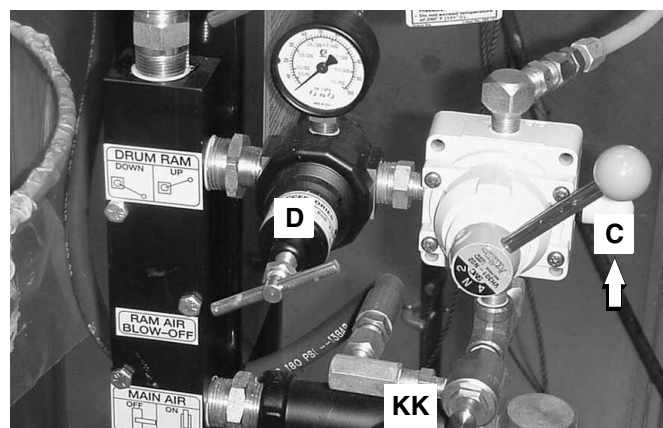

FIG. 29

4. Push and hold the ram separation air button (KK).
5. Adjust the ram regulator (D) to approximately 10-15 psi (69-103 kPa, 0.7-1 bar) or until the ram plate begins to rise.
6. Continue to hold the drum separation air button (KK) just enough to keep the drum from rising with the ram plate.
7. Follow the procedure to load material, pages 17-22.



You only need to lubricate the ram plate tire seals the first time you load material.

Changing Catalyst Pail

If you are using a ram and pump to supply catalyst, the procedure to change the pail is the same as changing the resin drum except that you use the controls on the back of the pail ram.

Filling Catalyst Pressure Tank

If you are using a pressure tank to supply catalyst, check the catalyst tank level with a metal or plastic rod whenever the resin drum is changed. To add catalyst to the tank, follow the procedure below.

1. Close the air supply shutoff valve (D), where the air tube connects to the tank air manifold. See FIG. 30.
2. Depressurize the tank by opening the vent drain valve (B) on the air manifold.
3. Unscrew the fill port cap (38).

⚠ CAUTION
Do not leave the tank open, exposed to the moisture in the air, or the catalyst will crystallize. The tank cover is normally only removed for tank cleaning.

4. Gently roll an unopened pail of catalyst on the floor for several revolutions to mix it.
5. Open the pail outlet and carefully pour the catalyst into the tank through a funnel.
6. Close the vent drain valve (B) and screw on the cap (38).
7. Make sure the silica-gel is blue in the desiccant air dryer. If the gel is pink, replace it (part no. 106498) or bake out the moisture.
8. Pressurize the tank with dried air by opening the catalyst air shutoff valve and the pressure tank air shutoff valve (D).

Key:

- A Desiccant filter (air dryer)
- B Vent drain valve
- C Pressure Relief Valve
- D Air shutoff valve
- 14 Dry air line
- 16 Fluid outlet shutoff valve
- 20 Fluid return line
- 21 Fluid line to metering pump
- 38 Fill port cap

⚠ Arrow points toward tank

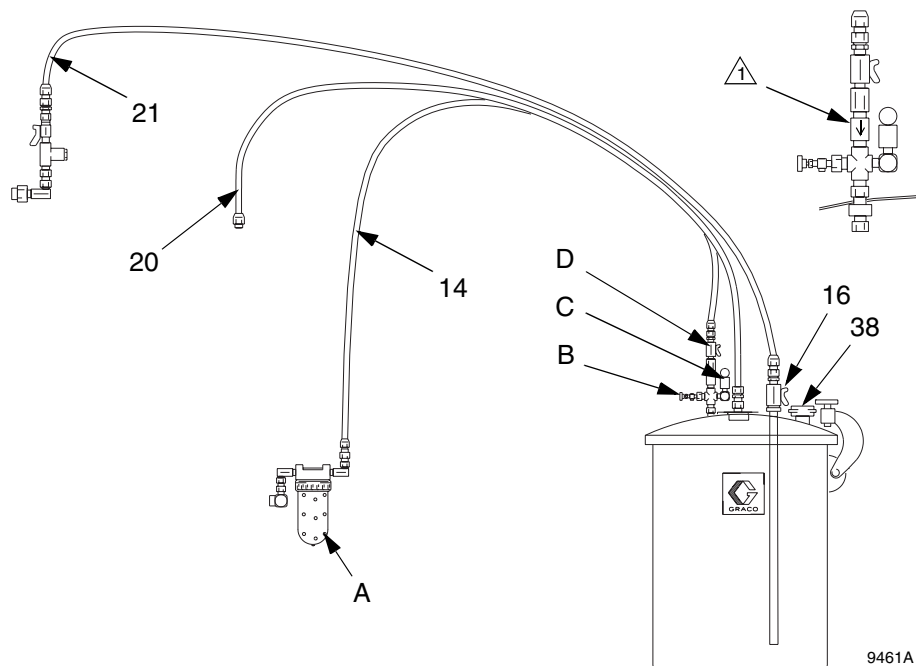

FIG. 30

Troubleshooting

Hydra-Mate Operating Pressures

There are three fluid pressure gauges on a typical Hydra-Mate system. They are mounted on:

- Catalyst slave pump support base
- Resin outlet block
- Catalyst outlet block

What the fluid gauges tell you

Catalyst Inlet Gauge

The catalyst slave pump inlet pressure gauge shows whether there is sufficient catalyst supply to reliably feed the slave pump during its intake stroke.

These double-acting pumps dispense fluid on both strokes, but load only on the stroke when the displacement rod is pulled out of the cylinder. That means that during the intake stroke, the fluid loads into the cylinder at twice the output rate.

When the main pump is on the downstroke, the slave pump is on the loading stroke. Watch the gauge when the linkage is pulling the pump housing down. The inlet gauge reading will drop while the pump is loading. The gauge should never drop to zero.

The catalyst supply air pressure should be set high enough to maintain a reliable slave pump feed pressure but no higher than necessary.

Resin Pump Outlet Gauge

The resin pump outlet gauge shows two different conditions, *stalled* and *running*.

- **Stalled:** With the pump air valve on and the gun closed, the gauge will show full stall pressure. This pressure is the fluid to air pressure ratio of the pump assembly, times the air pressure from the main regulator, minus the friction loss of the motor and pump assembly.

The fluid to air pressure ratio changes with different motors, different pumps, and different ratio settings. Output Charts, beginning on page 13, show the fluid/air ratio for your equipment at different ratios.

Example (most common):

The Bulldog air motor with the 222639 resin pump and the 222017 slave pump, at a 12.5:1 mix ratio, has a fluid/air ratio of 27:1. This means that at 100 psi (0.7 MPa, 7 bar) of air, the pumps will generate 2700 psi (19 MPa, 186 bar). Normal friction losses with mastic materials will use up 5-15% of that force, resulting in an actual stall pressure of 2300-2565 psi (16-18 MPa, 159-177 bar).

A similar King air motor powered unit would have a fluid/air pressure ratio of 54:1. 50 psi (345 kPa, 3.4 bar) of air provides the same results as above.

- **Running:** While running, the gauge reads the flow-induced pressure drop between the gauge and the gun outlet. All the motor power is used up by the time the fluid exits the gun. The pressure drop is a measure of friction loss caused by hoses, fittings, mixers, gun, and gunning block.

The difference in the gauge reading between the stall condition and running is the amount of dynamic friction loss from the pump assembly, plus the flow-induced pressure drop from the pump lower to the pressure gauge.

Viscosity, temperature, flow rate, and gun setup can affect the amount of gauge drop when the trigger is pulled. On a typical manual gun system, the gauge drops 100-400 psi (0.7-2.8 MPa, 7-28 bar). On systems where the motor is piloted with a signal from the gun, there is no significant gauge drop.

Catalyst Pump Outlet Gauge

The catalyst gauge shows line pressure, but the catalyst pressure is mainly generated as a reaction to resin pressure at the mix manifold.

Catalyst cannot open the check (injector) valve until its pressure equals resin pressure at the check valve. Hoses and injector restriction are chosen to naturally balance the pressure drop while running and match the catalyst pressure in the line when stalled.

Changeovers

When the pumps change direction there is a momentary change in gauges. In general, the gauges will drop 5-15%, then return. However, many factors affect the actual fluctuation, such as pump selection, fluid characteristics, flow rate, temperature, and length of hoses.

Check valves near the pump outlets isolate the hoses to let them serve as momentary surge chambers. This is why flow from the gun is smooth during changeover.

Abnormal Readings

Since so many factors affect gauge readings, it is important to know what is normal. Note how your gauges read when the machine is setup and running a good mix with no soft spots. What are the stall pressures and what are the running pressures for a given inbound air pressure? How much drop is there on changeover?

If something goes wrong, a change on the gauges can indicate what the problem is. Note those changes and work through the troubleshooting guide, page 29.

Air Supply Troubleshooting Chart

Problem	Cause	Solution
Abnormal pressure loss on air motor pressure regulator gauge during both changeovers.	Air line restriction due to quick-disconnect pin fitting.	Remove quick-disconnect from the air line and replace it with bleed-type air shutoff valve.
Abnormal master and slave pump outlet pressure loss during both changeovers.	Air supply line ID is too small.	Replace with minimum 3/4 in. (19 mm) ID hose.
Reduced flow rate.	Undersized air compressor.	Replace with properly sized air compressor.
Off-ratio material or poor mix quality.		

During normal operating conditions, the Hydra-Mate air motor is filled with air almost instantaneously on both changeovers.

However, if the Hydra-Mate air supply is restricted, it can take significantly longer for air to fill the air motor. To check for this, observe the gauge on the air motor pressure regulator during both changeovers:

- At the end of each stroke the air pressure will drop abnormally as the air motor begins to fill.
- At the same time the master and slave pump outlet pressures will drop abnormally due to the air motor's reduced pressure.

- The decrease in the pump outlet pressures causes the flow rate at the dispense gun to be reduced.
- Once the air motor has filled with air, all air pressures and flow rates will return to normal until the end of the next stroke.
- The decreased pump outlet pressure may affect the pumps' checking action, and thus mix ratio, resulting in the dispense of what appears to be poorly mixed material.
- Changing air pressure changes the compression of the resin hose and material. This causes an off ratio condition until pressures stabilize. Equipment air supply pressure must always stay above the motor regulator setpoint.

Pump Troubleshooting Overview

The following information explains common causes of pump problems. The **Master Pump Troubleshooting Chart** is on page 33. The **Slave Pump Troubleshooting Chart** is on page 34.

Pump Cavitation

Under normal operation, the force generated by the Hydra-Mate air motor is absorbed by the master and slave pumps. The result is near equal master and slave pump outlet pressures.

When the master or slave pump outlet pressure drops, such as during a pump malfunction, it absorbs less force than normal from the air motor. This excess force is absorbed by the other (non-failing) pump and its outlet pressure increases.

For instance, a Hydra-Mate set for a 12:1 ratio develops a master pump malfunction, causing its outlet pressure to drop 2000 psi (14 MPa, 138 bar). This causes the slave pump outlet pressure to increase by 12 x 2000, which equals 24,000 psi (165 MPa, 1655 bar). Consequently, the slave pump pressure relief valve discharges.

If the slave pump malfunctions in this scenario, the master pump outlet pressure will increase by 1/12 x 2000, which equals 166 psi (1.1 MPa, 11 bar), which may not appear as an obvious or abnormal pressure increase.

If the master or slave pump does not completely fill with material on an upstroke, the failing pump's material output is interrupted at the beginning of the next downstroke. This is referred to as *cavitation* or *diving*.

Master pump cavitation is detected by observing the master and slave pumps' outlet pressure gauges immediately after the master pump top changeover. When cavitation occurs, the master pump outlet pressure gauge drops and the slave pump outlet pressure gauge shows an increase in pressure, as described previously.

Slave pump cavitation is detected by observing the slave pump outlet pressure gauge immediately after the slave pump top changeover. When cavitation occurs, the slave pump outlet pressure gauge drops.



The slave pump top changeover is the master pump bottom changeover. This is because the pump is driven by moving the cylinder instead of the rod.

If the amount of cavitation is moderate, the pressure gauges return to their normal readings at some point during the downstroke of the failing pump. If the duration of cavitation is very short, the pump outlet pressure gauge shows an abnormal drop at the beginning of the downstroke, but may not drop completely to zero.

During master pump cavitation, the pressure drop may cause a noticeable reduction in flow rate at the dispense gun. Additionally, the interruption in the master pump material output may cause catalyst rich material to dispense, which may appear as poorly mixed material.

During slave pump cavitation, the interruption in the slave pump material output may cause resin rich material to dispense, which may appear as poorly mixed material. A worn Hydra-Mate linkage can slow the slave pump changeover and thus give the appearance of cavitation.

Pump Failure to Seal

Under normal operation, the output of the master and slave pumps depends upon proper sealing of their internal packings and check valves.

If packings or check valves fail to seal properly, the pump material output, and thus the output pressure, is reduced. Depending on the location of the failure, the pressure reduction may occur on the pump upstroke, downstroke, or both strokes.

- Failure of the piston packings and piston check valves are indicated by reduced pump outlet pressure on the upstroke (as they seal only on the upstroke).
- Failure of the inlet check valve is indicated by reduced pump pressure on the downstroke (as it seals only on the downstroke).
- Failure of the throat packings is indicated by reduced pump pressure on both strokes (as they seal on both strokes).
- Significant failures are indicated by reduced pump pressure during dispense (as the material/pressure will bleed off quickly).
- Slight failures may be indicated by reduced pump pressure during stall periods (as it will take a longer period of time for the material/pressure to bleed off).
- Reduced flow rate at the dispense gun and poorly mixed (catalyst rich) dispensed material indicate reduced master pump output, caused by a master pump problem.
- Poorly mixed (catalyst poor) dispensed material indicates reduced slave pump output, caused by a slave pump problem.

Catalyst Fluid Filter

Under normal operating conditions, the catalyst filter (on the slave outlet line) prevents contaminants from reaching and possibly fouling the injector.

If the filter screen gets too dirty, it will act as a restrictor, causing increased slave pump outlet pressure. If the filter is completely plugged, resin alone is dispensed from the gun and the slave pump outlet pressure increases until the relief valve discharges.

Check the filter and replace or clean as required.

Catalyst Bypass Valve

Under normal operating conditions, the catalyst bypass valve directs catalyst from the slave pump outlet back to the feed supply container only when resin purging the mixer.

However, if the valve is not closed or leaks during dispense, proportioned catalyst is allowed to return to the feed supply container. This provides less restriction at the slave pump outlet and decreases the pump outlet pressure. Since a reduced volume of catalyst is reaching the mix manifold, poorly mixed material is dispensed and its cure time is longer than normal.

Catalyst Pressure Relief Valve

The proportioner includes a spring-loaded, overpressure relief valve, which bypasses catalyst back to the supply when pressures exceed 3400 psi (23 MPa, 234 bar).

Catalyst Rupture Disc

This is an overpressure safety backup to the catalyst pressure relief valve. At 5000 psi (34 MPa, 345 bar), the disc will rupture and relieve catalyst into the bottle on the ram base plate. If the pressure relief valve is rebuilt or replaced, the disc must be replaced.

Master Pump Troubleshooting Chart

Problem	Cause	Solution
Abnormal master pump pressure drop and slave pump pressure increase immediately following master pump top changeover.	Cavitation due to damaged drum restricting travel of ram plate.	Replace drum.
Abnormally low master pump outlet pressures and abnormally high slave pump outlet pressures during master pump upstroke and/or downstroke.	Worn or damaged master pump packings.	Replace packings.
Master pump outlet pressure drops significantly and slave pump outlet pressure increases significantly during stall periods.	Malfunctioning master pump check valves (piston check valve if on the upstroke; inlet check valve if on the downstroke).	Clean or replace check valves.
Reduced flow rate.	Cavitation due to air entrapped in resin.	Purge all air from material lines, master pump, and ram plate, as detailed in startup procedures.
	Malfunctioning master pump check valves.	Clean or replace check valves.
	Base pump binding. A pressure pocket of resin has developed between the v-packings.	Replace piston packings with kit 686604.
Poor mix quality.	Cavitation due to ram air control valve not in DOWN position.	Place control valve in DOWN position.
	Cavitation due to low ram air pressure.	Increase to required operating pressure.
Poor mix quality - component B rich.	Malfunctioning master pump check valves.	Clean or replace check valves.
Low output gauge pressure for a given inlet air pressure.	Piston packings are too tight, causing excessive friction.	Clean and rebuild the master pump. For some applications, solid packing repair kit 686604 may work best.
Stall pressure lower than normal.	A pressure pocket of resin has developed between v-packings.	Replace piston packings with kit 686604.
Soft spots or color change relating to changeovers.	A pressure pocket of resin has developed between v-packings.	Replace piston packings with kit 686604.
	Air trapped in base material making it compressible.	Check for tiny bubbles in cured material. Replace drum.

Slave Pump Troubleshooting Chart

Problem	Cause	Solution
Abnormal slave pump pressure drop immediately following slave pump top changeover (bottom changeover of master pump).	Cavitation due to damaged catalyst container restricting travel of ram plate.	Replace container.
	Cavitation due to air entrapped in catalyst.	Purge all air from catalyst lines, feed pump, and ram plate, as detailed in startup procedures.
Abnormally low slave pump outlet pressures during slave pump upstroke and/or downstroke.	Worn or damaged slave pump packings.	Replace packings.
	Open or leaky catalyst bypass valve.	Close or repair/replace valve.
Slave pump outlet pressure drops significantly.	Malfunctioning slave pump check valves.	Clean or replace check valves.
Abnormally high slave pump outlet pressure.	Fouled or plugged catalyst filter.	Clean filter.
Poor mix quality - component B lean.	Cavitation due to feed pump ram air control valve not in DOWN position.	Place control valve in DOWN position.
	Cavitation due to low feed pump ram air pressure.	Increase to required operating pressure.
	Cavitation due to low feed pump air pressure.	Increase to required operating pressure.
	Worn Hydra-Mate linkage.	Replace linkage.
Poor mix quality - component B rich.	Malfunctioning slave pump check valves.	Clean or replace check valves.
Poor mix quality - excessive cure time.	Open or leaky catalyst bypass valve.	Close or repair/replace valve.
Low output gauge pressure for a given inlet air pressure.	Piston packings are too tight, causing excessive friction.	Clean and rebuild the master pump. For some applications, solid packing repair kit 686604 may work best.
Stall pressure lower than normal.	A pressure pocket of resin has developed between v-packings.	Clean and rebuild master pump. For some applications, solid packing repair kit 686604 may work best.
Soft spots or color change relating to changeovers.	A pressure pocket of resin has developed between v-packings.	Clean and rebuild master pump. For some applications, solid packing repair kit 686604 may work best.
	Air trapped in catalyst.	Purge return line on proportioner with catalyst pail pump.
	Air fed to slave pump with catalyst. Pickup tube in tank is loose or cracked.	Tighten or replace pickup tube.

Manifold/Mixer Troubleshooting Chart

Problem	Cause	Solution
Poor mix quality.	Dirty mixer.	Disassemble Tri-Core mixer, clean housing and end caps, and replace mix elements.
	Dirty mixer and gun.	Replace flex mixer or clean Tri-Core mixer and gun.
	Tri-core mixer assembled improperly.	Reassemble with scribe lines on end caps aligned.
	Fouled or plugged catalyst injector.	Clean or replace injector.
Reduced flow rate.	Dirty mixer.	Disassemble Tri-Core mixer, clean housing and end caps, and replace mix elements.
	Dirty mixer and gun.	Replace flex mixer or clean Tri-core mixer and gun.
	Leaking catalyst shutoff valve.	Repair or replace valve.
Poor purge quality.	Leaking catalyst shutoff valve.	Repair or replace valve.
Abnormally high slave pump outlet pressures.	Fouled or plugged catalyst injector.	Clean or replace injector.
Soft spots or color change relating to changeovers.	Motor is not being piloted when 2K UltraLite disposable mixer gun is used.	Flip air pilot bypass switch to NORMAL.

Tri-Core Mixer

Under normal operating conditions, the resin and catalyst are blended into a uniform mixture by mix elements contained in three passages in the Tri-Core mixer.

Over a period of time, residual mixed material from resin purging gradually builds up on the mix elements. This restriction may:

- Cause a noticeable reduction in the flow rate at the dispense gun.
- Reduce the mix elements efficiency, resulting in the dispense of poorly mixed material.

Check the Tri-Core mixer at the start of each day and whenever you stop dispensing for a period of time.

If the Tri-Core mixer is not assembled properly, the material will be blended only by the mix elements container in one passage and poorly mixed material dispenses.

Catalyst Shutoff Valve

Under normal operating conditions, during resin purge, the closed catalyst shutoff valve prevents catalyst from entering the mix manifold. This allows mixed material to be purged from the mix manifold, Tri-Core mixer, dispense gun, etc., by the uncatalyzed resin.

If the catalyst shutoff valve is not closed completely or leaks, catalyst can enter the mix manifold and contaminate the resin being purged. The result is visible traces of catalyst in the material dispensed from the gun.

Catalyst Injector

Under normal operating conditions, the catalyst injector provides the necessary pressure balance between the resin and catalyst material components to achieve the proper ratio and mix.

If the injector becomes fouled with mixed material, the pressure indicated on the slave pump outlet gauge will increase and upset the pressure balance, resulting in the dispense of poorly mixed material.

If the injector becomes completely plugged, resin alone is dispensed from the gun and the slave pump outlet pressure will increase until the relief valve discharges.

If the injector valve sticks, it can react sluggishly causing soft spots after valve triggering or changeover.

Keep the injector clean. Inspect the housing tip and needle end for dents or scratches. Lapping the needle to the housing with automotive lapping compound will recondition the seat/needle. When reassembling the injector, tighten the nut 2-2.5 turns after the slack is taken up

Parts

Part No. 953100 & 570312

Part No. 953100

25:1 Bulldog Pump, No. 7 Slave Pump, Configurator Model A-1

Part No. 570312

25:1 Bulldog Pump, No. 1 Slave Pump, Configurator Model A-2

Ref. No.	Part No.	Description	Qty.	Ref. No.	Part No.	Description	Qty.
1	902098	AIR MOTOR, Bulldog; see manual 307049	1	33	156849	NIPPLE; 3/8 npt	1
2	604099	ROD, connecting	1	35	155665	UNION, swivel, straight; 3/8 npt(m) x 3/8 npsm(f)	1
3	168211	NUT, connecting rod	1	36▲	180233	LABEL, warning	2
4	160028	O-RING	1	37	222017	PUMP, displacement, 953100 only ; see manual 307944	1
5	100103	PIN, cotter	2		948641	PUMP, displacement, 570312 only ; see manual 684004	1
6	222639	PUMP, displacement; see manual 307982	1				
7	168212	ROD, connecting, pump	1	38	100131	NUT; 3/8-16	4
8	101712	NUT, tie rod	3	39	100133	WASHER, spring lock; 3/8"	4
9	168210	NUT, shouldered	1	40	218029	FILTER, fluid; see manual 307273	1
10	168254	ROD, tie	3	41*	206734	KIT, repair, Bulldog Air Motor	1
11	157191	NIPPLE; 3/4 x 1/2 npt	2	42*	206995	THROAT SEAL LIQUID; 1 quart	1
12	214848	LUBRICATOR, air line; see manual 308169	1	43*	217374	ISO PUMP OIL; 1 pint	1
13	156589	UNION, swivel, 90°; 3/4 npt(f) x 3/4 npsm(f)	1	44*	222101	KIT, repair, pump	1
14	102806	UNION, swivel, 90°; 1" npt(m) x 1" npsm(f)	1	45*	236595	KIT, repair, pump	1
15	501254	HOSE, 1" (25 mm) ID x 34"	1	47	501867	VALVE, check; 1/4 npt(mbe)	1
18	101936	NUT, jam	1	48	162453	NIPPLE; 1/4 npt x 1/4 npsm	1
20	196079	RAM, pneumatic; includes item 29; see manual 306934	1	49▲	513106	LABEL, warning	1
21	512616	HOSE; PTFE; 1/4" ID x 18"; 1/4 npsm(f)	2	51▲	513068	LABEL, warning	1
22	100003	SCREW; 3/8-16 x 1-1/2"	4	52▲	513069	LABEL, warning	1
23	948094	CONTROL, air; see parts list on page 42	1	53	155570	UNION, swivel, straight; 1/4 npt(m) x 1/4 npsm(f)	1
24	501095	SPRING, intake valve	1	54	100840	ELBOW; 1/4 npt(m x f)	1
25	214037	VALVE, ball, catalyst bypass; 1/4 npt(mbe); see manual 306861	1	55*	102176	WRENCH, spanner	1
26	100176	BUSHING; 3/8 npt(m) x 1/4 npt(f)	1	56	150287	ADAPTER; 3/8 npt(f) x 1/4 npt(m)	1
27	903366	MODULE, ratio check; see parts list on page 44	1	57	112279	BOTTLE, drain	1
28	101501	SCREW; 1/4-20 x 1/2"	4	58	236272	HOLDER, bottle	1
29	902755	FRAME, Hydra-Mate; see parts list on page 43	1	▲ Replacement Danger and Warning labels, tags and cards are available at no cost.			
30	155699	ELBOW; 3/8 npt(m x f)	1	* Not shown in parts drawing.			
31	206831	VALVE, check; 3/8 npsm(f) inlet x 3/8 npt(m) outlet	1				
32	100721	PLUG, pipe; 1/4 npt	2				

Key:

A 1" npt(f) Fluid Outlet
 B From Catalyst Metering Pump
 C Return to Catalyst Supply
 D Rupture Disc Discharge Hose
 E From Catalyst Bypass Valve
 F 3/4 npt(f) Pump Inlet
 G To Relief Valve Drain

J Resin Outbound Pressure Gauge
 K Catalyst Outbound Pressure Gauge
 L Catalyst Bypass Valve
 M Proportioner Air Supply
 N Catalyst Feed Air Supply
 O Ram Air Supply

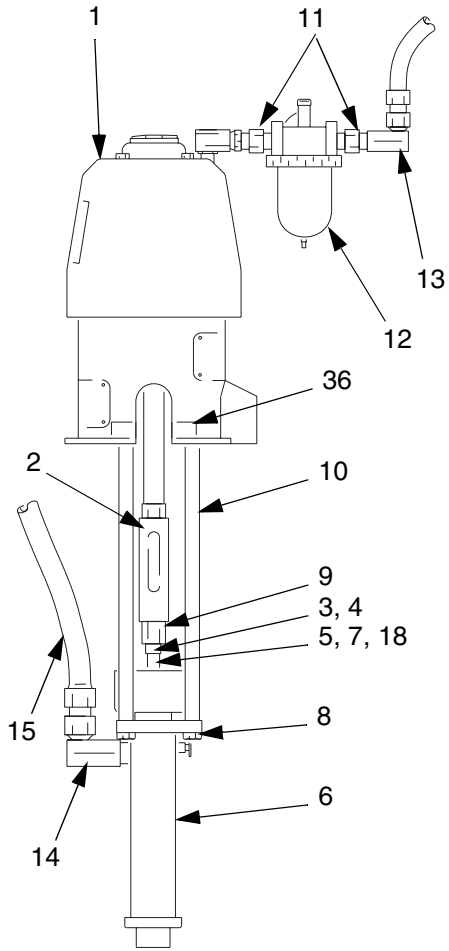

Master Pump Detail

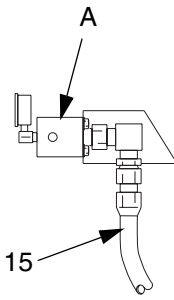

Resin Ratio Check Valve Detail

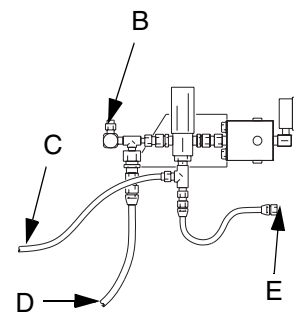

Catalyst Ratio Check Valve Detail

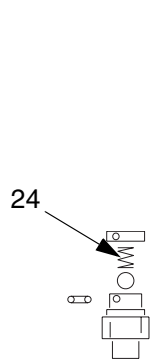

Inlet Valve Detail

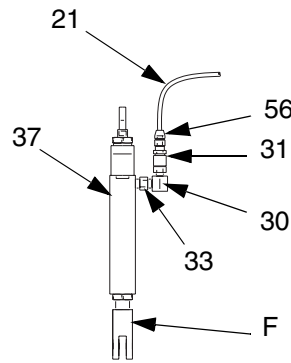

Catalyst Pump Detail

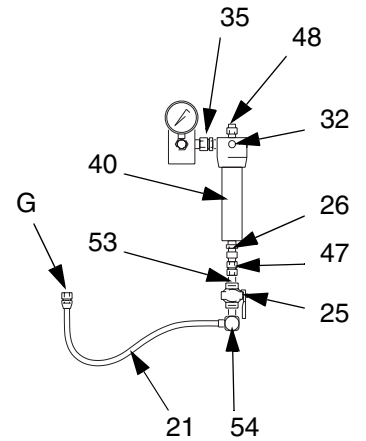

Catalyst Outlet Detail

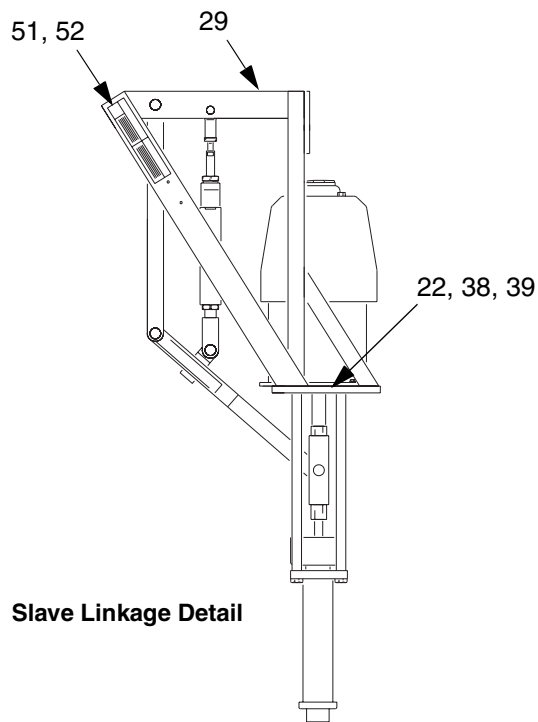

Slave Linkage Detail

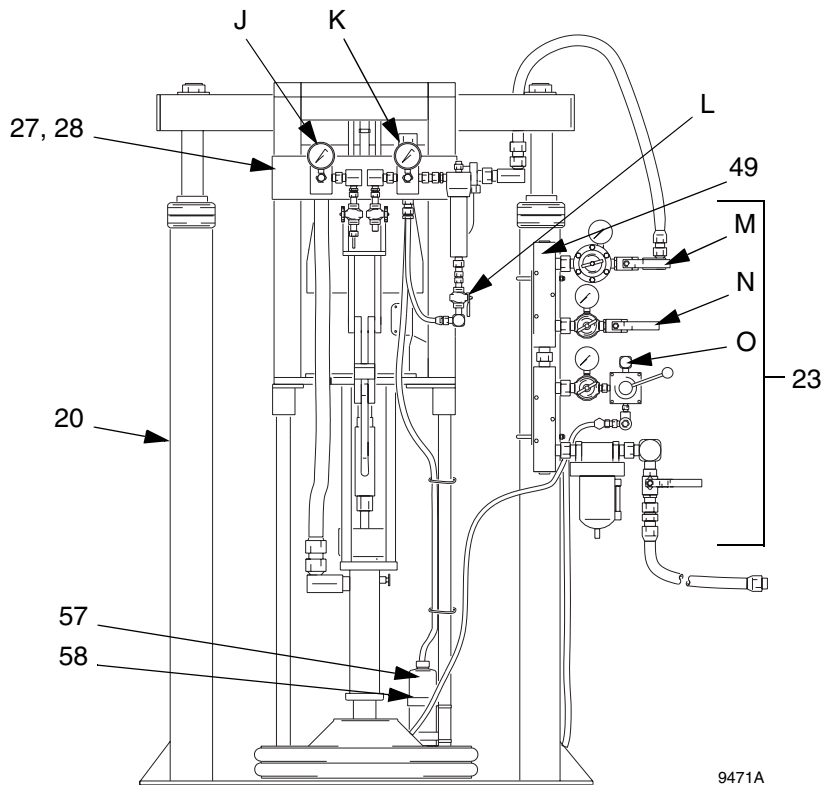

9471A

Part No. 954900 & 965580**Part No. 954900**

50:1 Quiet King Pump, No. 7 Slave Pump, Configurator Model A-3

Part No. 965580

50:1 Quiet King Pump, No. 5 Slave Pump, Configurator Model A-5

Ref. No.	Part No.	Description	Qty.	Ref. No.	Part No.	Description	Qty.
1	220106	AIR MOTOR, King; see manual 309348	1	35	155665	UNION, swivel, straight; 3/8 npt(m) x 3/8 npsm(f)	1
2	604099	ROD, connecting	1	36▲	180233	LABEL, warning	2
3	168211	NUT, connecting rod	1	37	222017	PUMP, displacement, 954900 only ; see manual 307944	1
4	160028	O-RING	1		222015	PUMP, displacement, 965580 only ; see manual 307944	1
5	100103	PIN, cotter	2	38	100131	NUT; 3/8-16	4
6	222639	PUMP, displacement; see manual 307982	1	39	100133	WASHER, spring lock; 3/8"	4
7	168212	ROD, connecting, pump	1	40	218029	FILTER, fluid; see manual 307273	1
8	101712	NUT, tie rod	3	41*	207730	KIT, repair, King Air Motor	1
9	168210	NUT, shouldered	1	42*	206995	THROAT SEAL LIQUID; 1 quart	1
10	168254	ROD, tie	3	43*	217374	ISO PUMP OIL; 1 pint	1
11	157191	NIPPLE; 3/4 x 1/2 npt	2	44*	222101	KIT, repair, pump	1
12	214848	LUBRICATOR, air line; see manual 308169	1	45*	236595	KIT, repair, pump	1
13	156589	UNION, swivel, 90°; 3/4 npt(f) x 3/4 npsm(f)	1	47	501867	VALVE, check; 1/4 npt(mbe)	1
14	102806	UNION, swivel, 90°; 1" npt(m) x 1" npsm(f)	1	48	162453	NIPPLE; 1/4 npt x 1/4 npsm	1
15	501254	HOSE, 1" (25 mm) ID x 34"	1	49▲	513106	LABEL, warning	1
18	101936	NUT, jam	1	51▲	513068	LABEL, warning	1
20	196079	RAM, pneumatic, 954900 only ; includes item 29; see manual 306934	1	52▲	513069	LABEL, warning	1
	196078	RAM, pneumatic, 965580 only ; includes item 29; see manual 306934	1	53	155570	UNION, swivel, straight; 1/4 npt(m) x 1/4 npsm(f)	1
21	512616	HOSE; PTFE; 1/4" ID x 18"; 1/4 npsm(f)	1	2			
22	100003	SCREW; 3/8-16 x 1-1/2"	4	54	100840	ELBOW; 1/4 npt (m x f)	1
23	948094	CONTROL, air; see parts list on page 42	1	55*	102176	WRENCH, spanner	1
24	501095	SPRING, intake valve	1	56	150287	ADAPTER; 3/8 npt(f) x 1/4 npt(m)	1
25	214037	VALVE, ball; 1/4 npt(mbe); see manual 306861	1	57	112279	BOTTLE, drain	1
26	100176	BUSHING; 3/8 npt(m) x 1/4 npt(f)	1	58	236272	HOLDER, bottle	1
27	903366	MODULE, ratio check; see parts list on page 44	1	62	157785	UNION, swivel, straight; 3/4 npt(m) x 3/4 npsm(f)	1
28	101501	SCREW; 1/4-20 x 1/2"	4	63	104984	TEE; 1/4 npt	1
29	902755	FRAME, Hydra-Mate; see parts list on page 43	1	64	156971	NIPPLE; 1/4 npt	1
30	155699	ELBOW; 3/8 npt (m x f)	1	65	502083	VALVE, relief; 65 psi	1
31	206831	VALVE, check; 3/8 npsm(f) inlet x 3/8 npt(m) outlet	1	▲ Replacement Danger and Warning labels, tags and cards are available at no cost.			
32	100721	PLUG, pipe; 1/4 npt	2	* Not shown in parts drawing.			
33	156849	NIPPLE; 3/8 npt	1				

Key:

A 1" npt(f) Fluid Outlet
 B From Catalyst Metering Pump
 C Return to Catalyst Supply
 D Rupture Disc Discharge Hose
 E From Catalyst Bypass Valve
 F 3/4 npt(f) Pump Inlet
 G To Relief Valve Drain

J Resin Outbound Pressure Gauge
 K Catalyst Outbound Pressure Gauge
 L Catalyst Bypass Valve
 M Proportioner Air Supply
 N Catalyst Feed Air Supply
 O Ram Air Supply

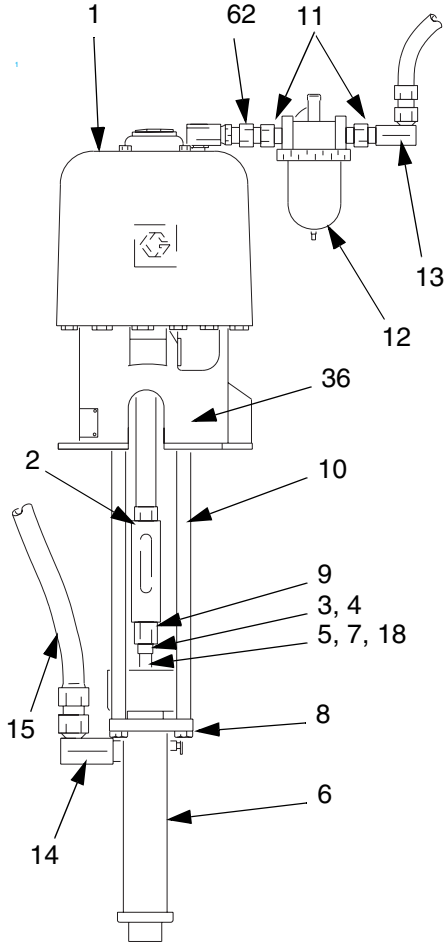

Master Pump Detail

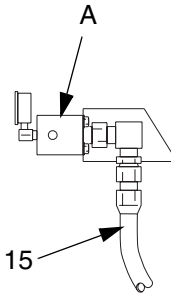

Resin Ratio Check Valve Detail

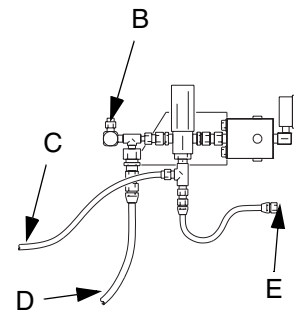

Catalyst Ratio Check Valve Detail

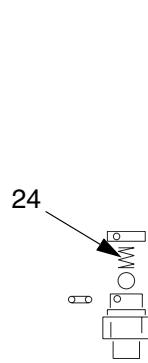

Inlet Valve Detail

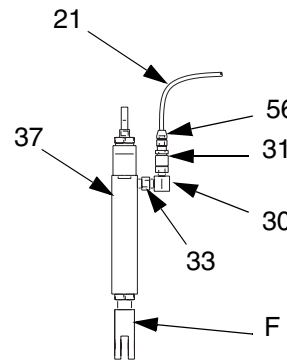

Catalyst Pump Detail

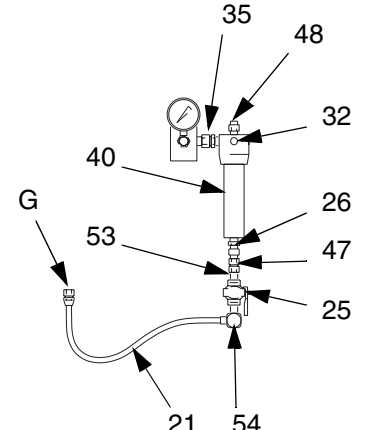

Catalyst Outlet Detail

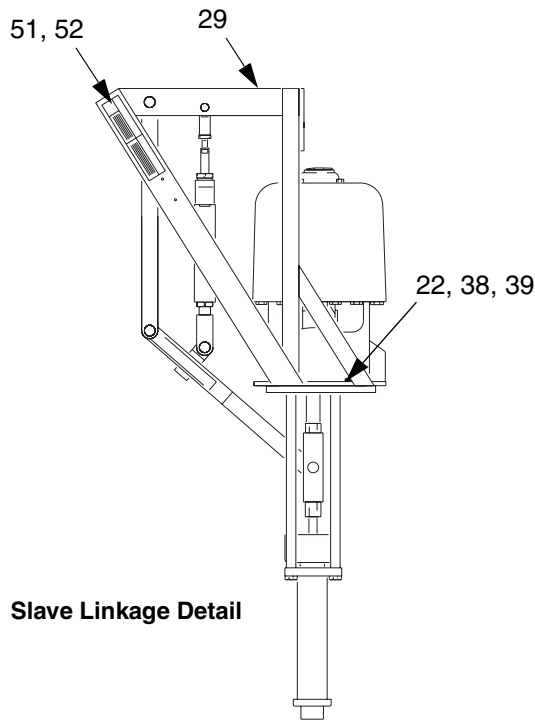

Slave Linkage Detail

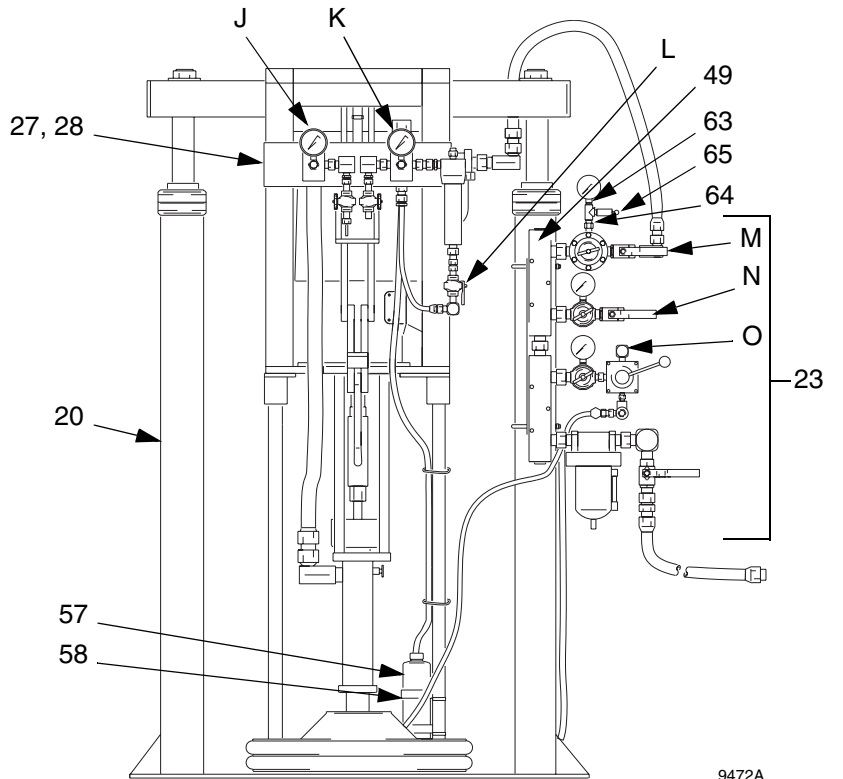

9472A

Part No. 948094

Air Control (all modules)

Ref. No.	Part No.	Description	Qty.	Ref. No.	Part No.	Description	Qty.
1	215635	HOSE, coupled; nylon; 1/4" ID; 1 ft. long	1	18	159842	ADAPTER; 1/2 npt(f) x 1/4 npt(m)	1
2	100015	NUT, hex; 1/4-20	6	19	160032	NIPPLE; 3/4 npt	2
3	100016	WASHER, lock; 1/4"	6	20	160430	GAUGE, air; 100 psi	3
4	100086	WASHER; 1/4"	6	21	162449	NIPPLE; 1/2 x 1/4 npt	1
5	100840	ELBOW; 1/4 npt (m x f)	2	22	166590	ELBOW; 3/4 npt (m x f)	1
6	102726	PLUG, pipe; 3/4 npt	2	23	171937	REGULATOR, air	2
7	104984	TEE; 1/4 npt	1	24	175013	NIPPLE; 3/4 npt	1
8	105170	SCREW, cap, hex hd; 1/4-20 x 2"	6	26	206197	REGULATOR, air	1
9	106150	FILTER, air	1	27	206727	VALVE, ram, air relief	1
10	107141	VALVE, air, bleed-type; 3/4 npt(m) inlet x 3/4 npt(f) outlet	1	28	214950	HOSE, air; 3/4" ID x 6 ft. long; 1/2 x 3/4 npt (mbe)	1
11	107142	VALVE, air, bleed-type; 1/2 npt(m) inlet x 1/2 npt(f) outlet	2	29	214955	HOSE, air; 3/4" ID x 10 ft. long; 3/4 npt (mbe)	1
12	151519	NIPPLE; 1/4 x 1/8 npt	1	30	C19407	FITTING, connector, male; 1/4 tube x 1/4npt	1
13	155470	UNION, swivel, straight; 1/4 npt(m) x 1/4 npsm(f)	1	31	512910	MUFFLER, polyethylene; 1/4 npt	1
14	156172	UNION, swivel, straight; 3/4 npt(f) x 3/4 npsm(f)	1	32	513004	VALVE, directional, air; 1/4 npt	1
15	156971	NIPPLE; 1/4 npt	2	33	595757	STOP, nut; 5/16"	4
16	157191	NIPPLE; 3/4 x 1/2 npt	3	34	602933	U-BOLT, ram mount	2
17	157676	UNION, swivel, 90°; 1/4 npt(f) x 1/4 npsm(f)	1	35	624225	MANIFOLD, air	2
				36	624226	BRACKET, air kit	1

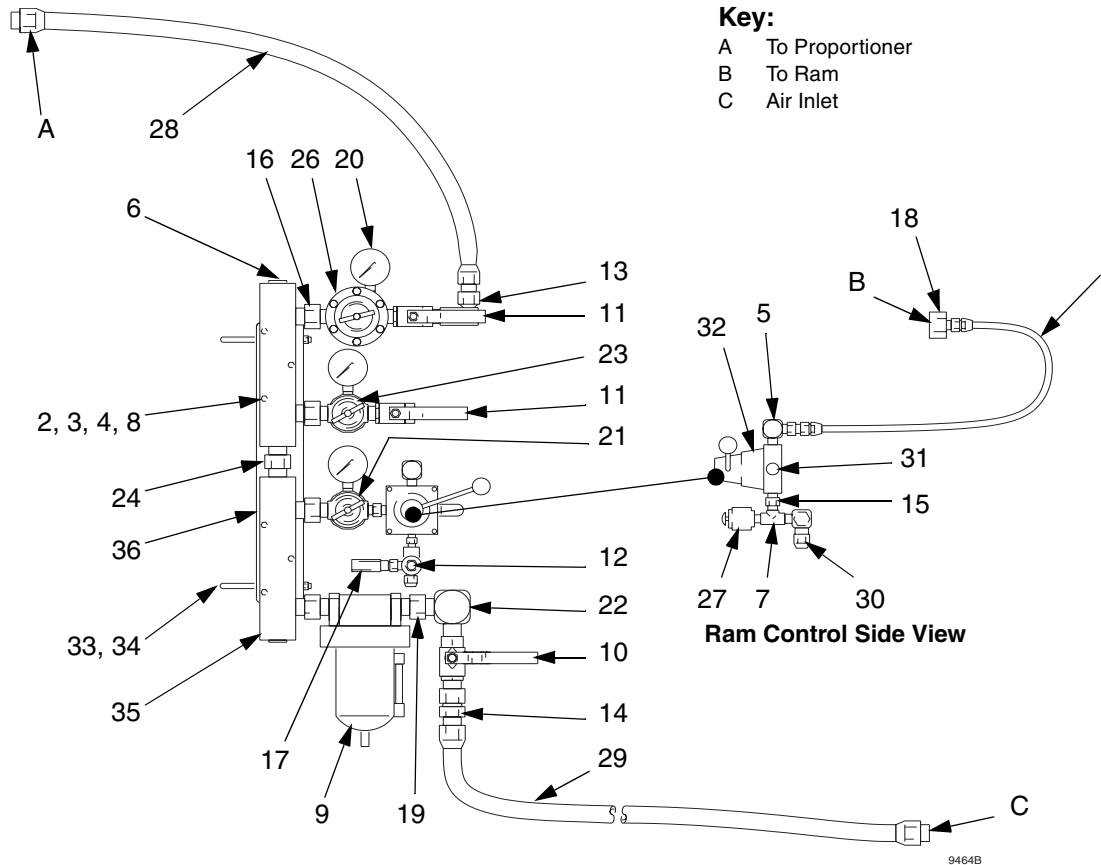

Part No. 902755

Hydra-Mate Frame Assembly (all modules)

Ref. No.	Part No.	Description	Qty.	Ref. No.	Part No.	Description	Qty.
3	100133	WASHER, lock	2	24	168422	CAP, tube	2
6	101051	RING, retaining	10	25	621466	SPACER, pin	1
7	501206	SCREW, socket hd	2	26	622120	ADAPTER; 1/2-20 x 3/4-16	1
8	501311	BEARING	12	27	621992	GAUGE, slave adjuster	1
11	621991	PLATE, slave	1	28	948204	KIT, accessory; includes 28a-28d, which are only available with kit	1
12	622121	SPACER	2	28a	-	• PIN	1
14	511137	BEARING, rod, end	1	28b	-	• PIN	2
17	607615	MANIFOLD, intake valve	1	28c	-	• PIN	1
19	902094	ADJUSTER	1	28d	-	• PIN	1
21	902096	SUPPORT	1	30	604094	ARM, front pivot	2
22	101845	SCREW; 6-32 x 3/8"	2	31	902093	ARM, lower link	1

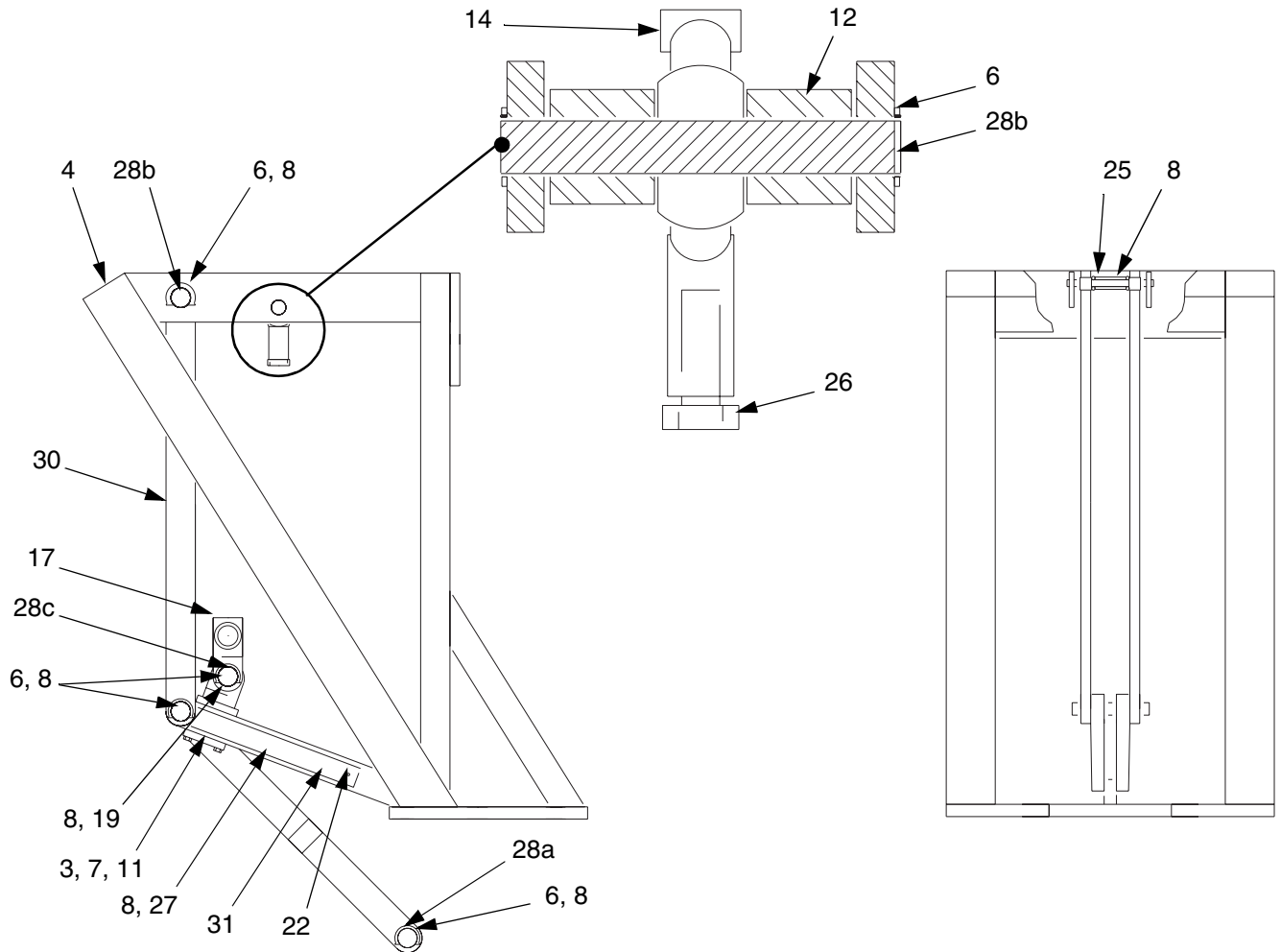

Part No. 903366

Ratio Check Module (all modules)

Ref. No.	Part No.	Description	Qty.	Ref. No.	Part No.	Description	Qty.
1	15A733	HOSE; nylon; 1/2" OD; 4 ft. long	1	14	104984	TEE; 1/4 npt	1
2	100040	PLUG; 3/8"	3	17	237062	VALVE, relief; see 308547	1
3	100057	SCREW; 5/16-18 X 3/4"	8	18	215622	VALVE, ball; 1/4 npt(mbe)	2
4	102814	GAUGE, fluid; 0-5000 psi	2	19	217562	LEVER, mix manifold	1
5	100840	ELBOW; 1/4 npt(m x f)	1	20	512334	PLUG, pipe	1
6	150286	BUSHING; 3/8 npt(f) x 3/8 npt(m)	2	21	512612	HOUSING, disc rupture	1
7	156684	UNION, swivel, straight; 1/2 npt(m) x 1/2 npsm(f)	2	24	512613	DIAPHRAGM, package of 3	1
8	156022	ADAPTER; 3/8 npt(m) x 1/2 npt(f)	1	25	604357	BRACKET, ratio check	1
9	156823	UNION, swivel, straight; 1/4 npt(m) x 1/4 npsm(f)	2	26	623892	MANIFOLD, ratio check; 1" npt	1
10	156849	NIPPLE; 3/8 npt	1	27	623893	MANIFOLD, ratio check; 3/8 npt	1
11	156971	NIPPLE; 1/4 npt	1	28	947894	VALVE, check; 1" npsm(f) x 1" npt(f)	1
12	158585	NIPPLE; 1" npt	1	29	103475	TEE; 1/2 npt	1
13	164259	ELBOW; 3/8 npt(m) x 1/4 npt(f)	4	30	162449	NIPPLE; 1/2 x 1/4 npt	3
				31	158979	NIPPLE; 1/2 npt x 3/8 npt	1
				32	100214	WASHER, lock; 5/16"	8

Key:

- A 1" npt(f) Fluid Outlet
- B 1" npt(f) Fluid Inlet
- C 1/4 npt(f) Fluid Inlet
- D 1/4 npt Inlet
- E 1/2 npt Outlet
- F 3/8 npt(f) Fluid Outlet

- 28 Resin Check Valve
- 17 Catalyst Pressure Relief Valve
- 18 Sample Valves, see manual 309207 for ratio check information

 Install diaphragm (24) with its protrusion facing down into the housing (21). Be careful not to damage it.

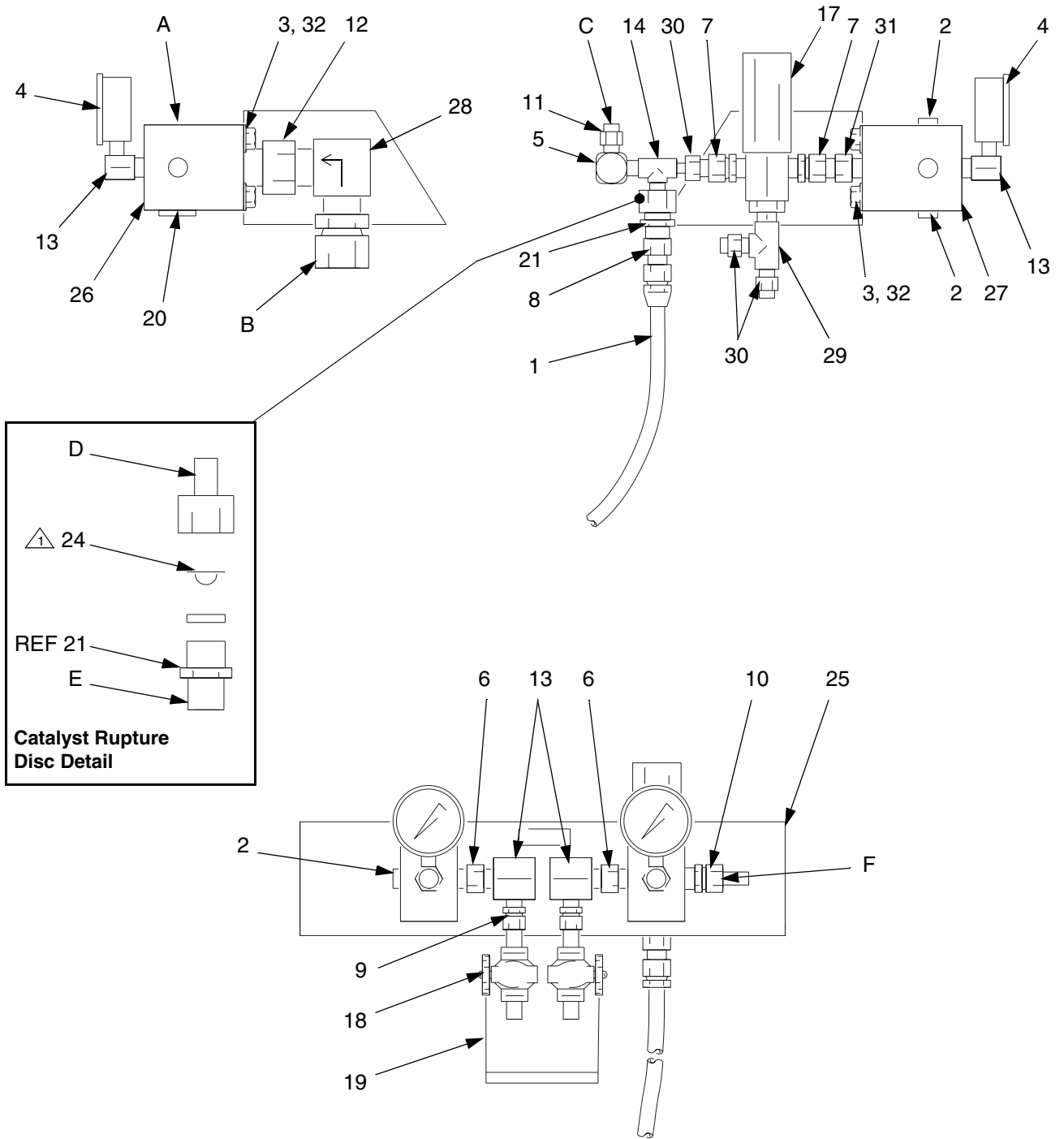

9463A



Part No. 954855

5:1 Monark Supply Pump on 5 Gallon Ram, Configurator Model Option B-1

Ref. No.	Part No.	Description	Qty.	Ref. No.	Part No.	Description	Qty.
1	15A732	HOSE; buna-S; 1/4" ID; 10 ft. long	1	27	157785	UNION, swivel, straight; 3/4 npt(m) x 3/4 npsm(f)	1
3	109477	SCREW; 5/16-18 x 1/2"	2	28	160327	UNION, swivel, 90°; 3/4 npt(m) x 3/4 npsm(f)	2
4	103473	STRAP, tie	5				
6	100101	SCREW; 3/8-16 x 1"	4	29	100175	COUPLING; 1/4 npt	1
7	100133	WASHER, spring lock; 3/8"	4	30	160721	O-RING; buna-N	1
8	100195	NIPPLE 3/8 npt	1	31	214848	LUBRICATOR, air line; see manual 308169	1
9	626253	ADAPTER	1	33	113034	FITTING, tube; 1/4 npt(m) x 1/4 in. OD tube	1
10	190128	PLUG, valve	1	35	205997	AIR MOTOR, Monark; see 307043	1
11	100840	ELBOW; 1/4 npt (m x f)	2	36	113208	FITTING, tube; 1/8 npt(m) x 1/4 in. OD tube	1
12	165702	HOUSING, valve	1	37	206450	RAM, 5 gallon; see manual 306838	1
13	100615	BUSHING; 3/4 npt(m) x 1/4 npt(f)	1	38*	206728	KIT, repair, air motor	1
14	101078	FILTER, fluid, Y-line; 3/4 npt (fbe)	1	39	222812	PLATE, inductor; see manual 308049	1
15	101566	NUT, lock; 3/8-16	3	40	208391	VALVE, ball; 3/8 npt(m x f)	1
16	101946	PIN, cotter	2	41	214656	HOSE, air; 1/2" ID; 10 ft. long; 1/2 npt(mbe)	1
17	104984	TEE; 1/4 npt	1	42*	904555	KIT, repair, pump	1
18	-	TUBE; nylon; 1/4 in. OD; 2 ft. long; purchase locally	1	43	965084	PUMP, displacement; see manual 307430 for parts	1
19	105770	GAUGE, fluid; 0-1000 psi, not shown - installed on proportioner module	1	44*	217374	ISO PUMP OIL; 1 pint	1
20	156877	NIPPLE; 1/2 npt	1	45	106495	VALVE, check	2
22	155470	UNION, swivel, 90°; 1/2 npt(m) x 1/2 npsm(f)	2	46	624264	ROD, connecting	1
				47	624506	ROD, tie	3
23	156022	ADAPTER; 3/8 npt(m) x 1/2 npt(f)	1	48	186071	PLATE, adapter, ram	1
24	156971	NIPPLE; 1/4 npt	1	49	552231	HOSE; PTFE; 1/4 in. x 12 ft.; 1/4 npsm(fbe)	1
25	157191	NIPPLE; 3/4 x 1/2 npt	1	50	947092	HOSE; 10 ft.; 3/4 npt(mbe)	1
26	151519	NIPPLE; 1/4 x 1/8 npt	1				

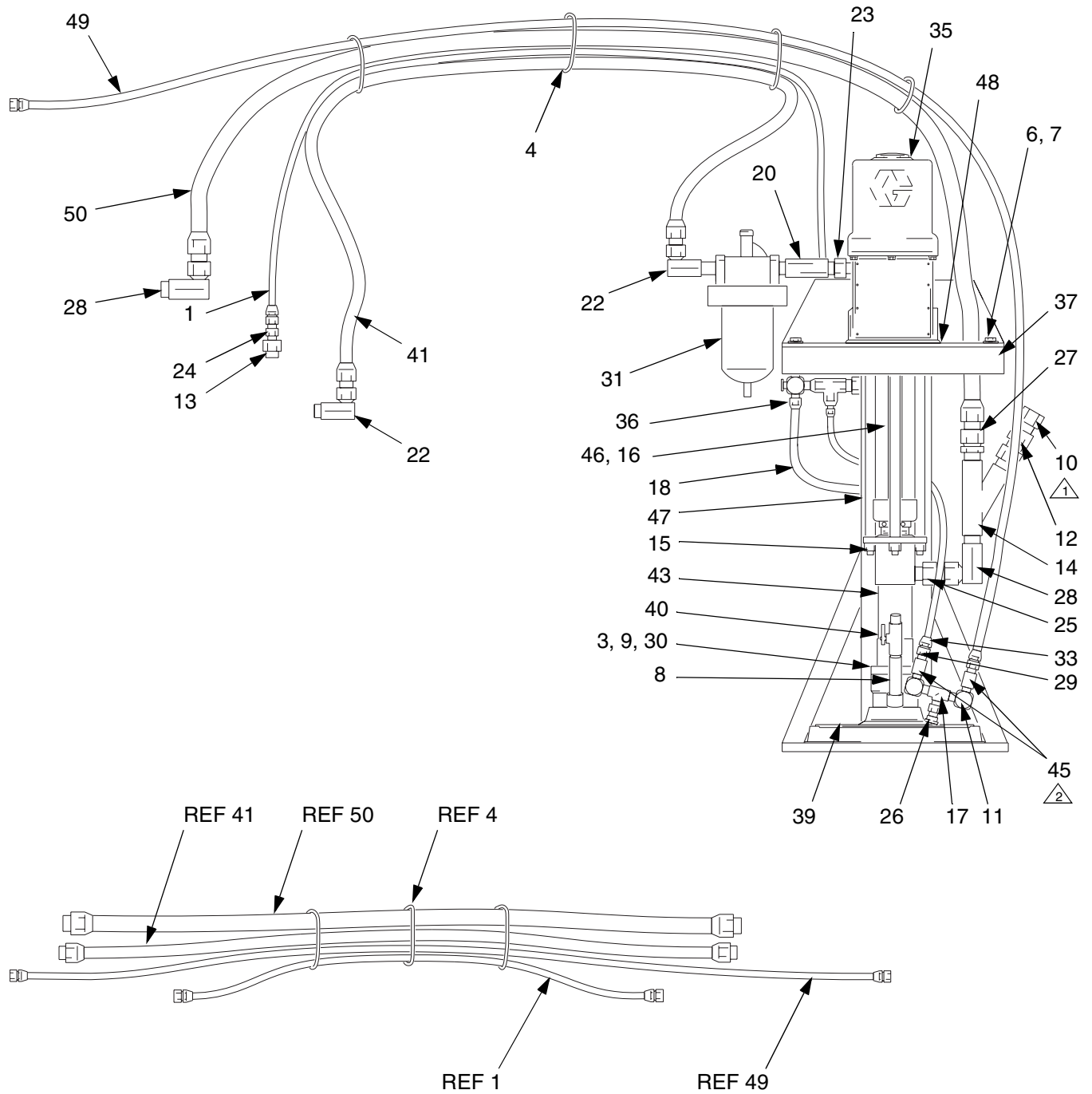
* Not shown in parts drawing.



-  Bleed valve
-  Check valves - arrows point into pail

9462A

Part No. 948109

5 Gallon Pressure Tank Supply, Configurator Model Option B-2

Ref. No.	Part No.	Description	Qty.	Ref. No.	Part No.	Description	Qty.
1	157350	NIPPLE; 3/8 x 1/4 npt	2	18	510896	FILTER, desiccant dryer	1
2	100505	BUSHING; 3/4 npt(m) x 3/8 npt(f)	1	19	623522	PLUG; 3/8" port	1
3	162453	NIPPLE; 1/4 npt x 1/4 npsm	3	20	947077	HOSE; 1/4 npsm(f); 10 ft.	1
4	155494	UNION, swivel, 90°; 3/8 npt(m) x 3/8 npsm(f)	1	21	947082	HOSE; 3/8 npt(mbe); 10 ft.	1
5	155541	UNION, swivel, 90°; 1/4 npt(m) x 1/4 npsm(f)	2	23	188784	NUT, jam, hex	1
6	106495	VALVE, check	1	24	112306	PLUG; 3/8 npt	1
7	155665	UNION, swivel, straight; 3/8 npt(m) x 3/8 npsm(f)	2	25	102959	CROSS; 1/4 npt	1
8*	106498	DESICCANT; 1 quart	1	27	100840	ELBOW; 1/4 npt(m x f)	1
9	156849	NIPPLE; 3/8 npt	1	30	103347	VALVE, relief; 100 psi	1
10	171796	TUBE, siphon	1	31	100030	BUSHING; 1/4 npt(m) x 1/8 npt(f)	1
11	166999	ELBOW, street; 1/2 npt(m) x 1/4 npt(f)	1	32	101759	FITTING, drain cock	1
12	187873	GAUGE, pressure; not shown - installed on proportioner module	1	33	100175	COUPLING, hex; 1/4 npt(f)	1
13	240417	STRAINER	1	34	208390	VALVE, ball; 1/4 npt (mbe)	1
14	215636	HOSE; nylon; 1/4" ID; 10 ft.	1	36	103414	O-RING	1
15	236087	PRESSURE TANK, bare; 5 gallon; see manual 308369	1	37	171988	GASKET	1
16	237534	VALVE, ball	2	38	210575	CAP, filler	1
				39	111329	LINER, 5 gallon	1

* Not shown in parts drawing.

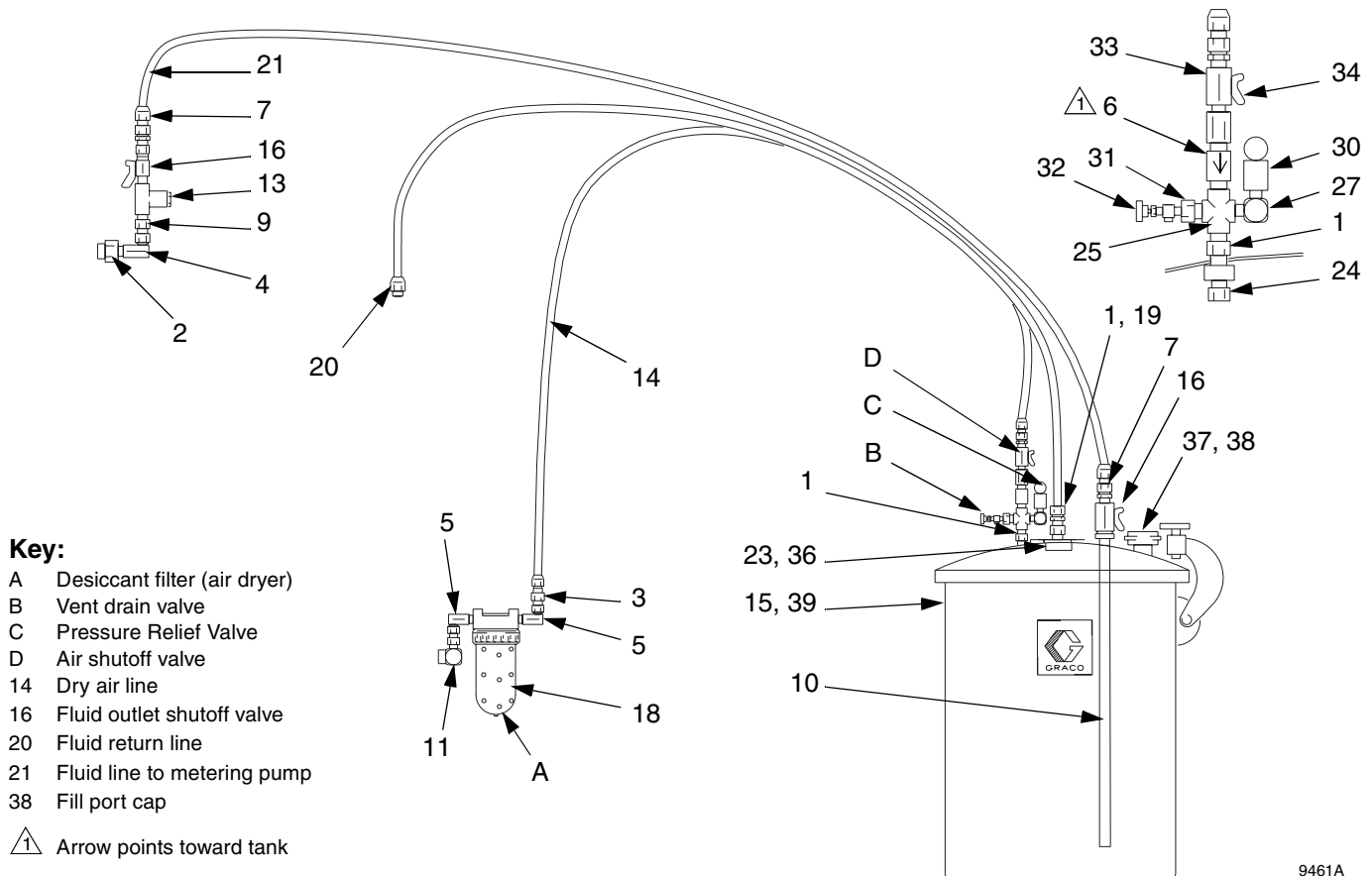

9461A

Part No. 570293

Boom Kit, for silicones or urethanes, Configurator Model Option C-1

Ref. No.	Part No.	Description	Qty.	Ref. No.	Part No.	Description	Qty.
1	947039	KIT, boom; see page 51	1	7	100056	NUT, jam; 7/8-14	1
2	100896	BUSHING; 3/4 npt(m) x 1/2 npt(f)	1	8	552231	HOSE, PTFE; 1/4 ID; 12 ft.	2
3	157262	WASHER	2	9	500946	HOSE; 1" ID; 10 ft.	1
4	202966	UNION; 3/4 npt(f) x 1" npt(f)	1	10	622070	BRACKET, hose mount	1
5	606937	BULKHEAD; 3/4" OD; 1/4 npt(fbe)	1	11	166590	ELBOW; 3/4 npt (m x f)	1
6	155495	ELBOW; 1/4 npt(m x f)	1	12	156971	NIPPLE; 1/4 npt	2
				13	160022	UNION; 1" npt(m) x 1" npsm(f)	1

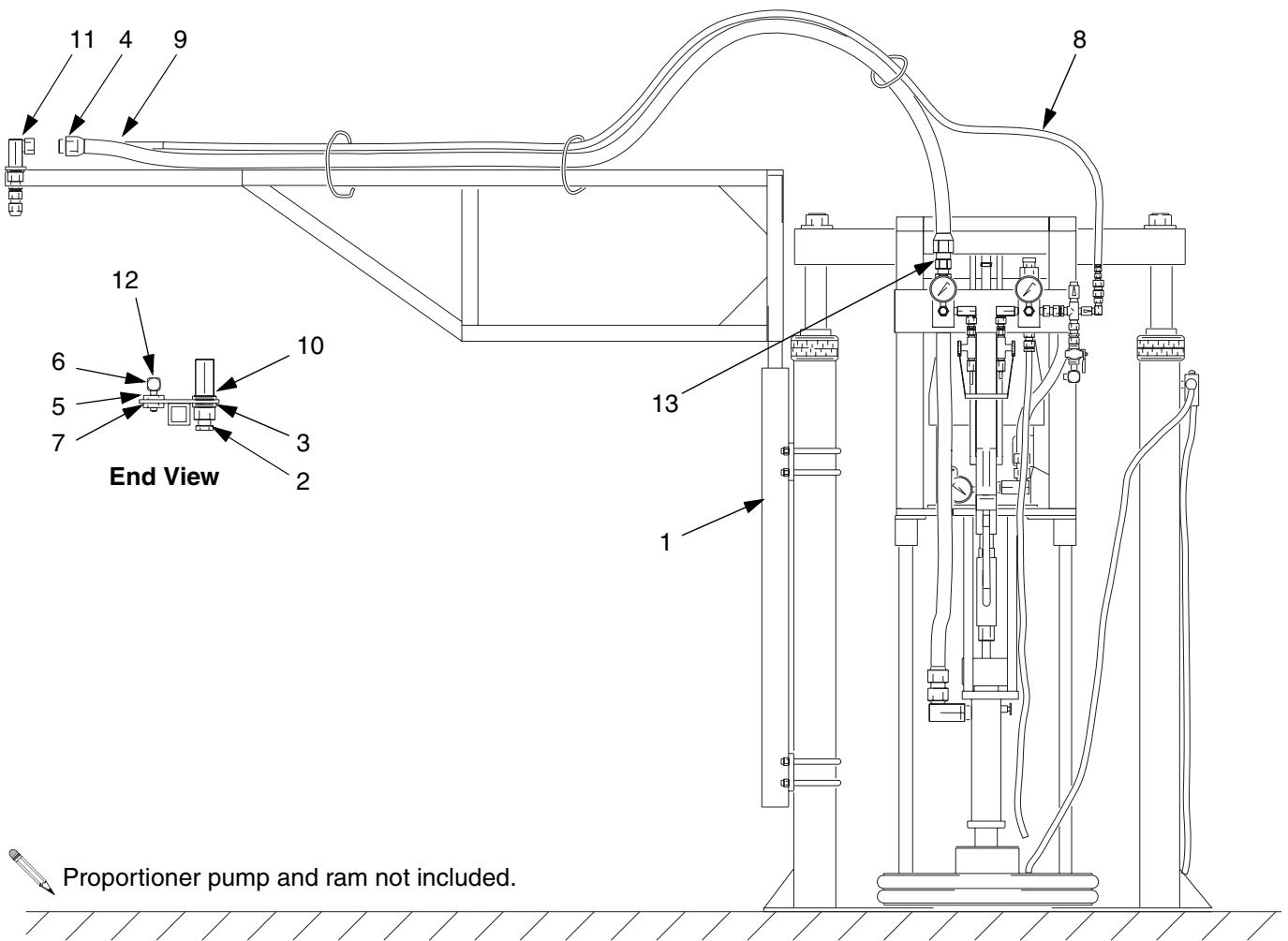

9467A

Part No. 570039

Boom Kit, for polysulfides, Configurator Model Option C-2

Ref. No.	Part No.	Description	Qty.	Ref. No.	Part No.	Description	Qty.
1	947039	KIT, boom; see page 51	1	7	100056	NUT, jam; 7/8-14	1
2	100896	BUSHING; 3/4 npt(m) x 1/2 npt(f)	1	8	552232	HOSE, PTFE; 3/8 ID; 12 ft.	1
3	157262	WASHER	2	9	500946	HOSE; 1" ID	1
4	202966	UNION; 3/4 npt(f) x 1" npt(f)	1	10	626596	BRACKET, bulkhead	1
5	606937	BULKHEAD; 3/8 npt (fbe)	1	12	159153	UNION; 3/8 npt(f) x 1/4 npsm(f)	1
6	155494	UNION, swivel, 90°; 3/8 npt(m) x 3/8 npsm(f)	1	13	160022	UNION; 1" npt(m) x 1" npsm(f)	1
				14	166590	ELBOW; 3/4 npt(m x f)	1

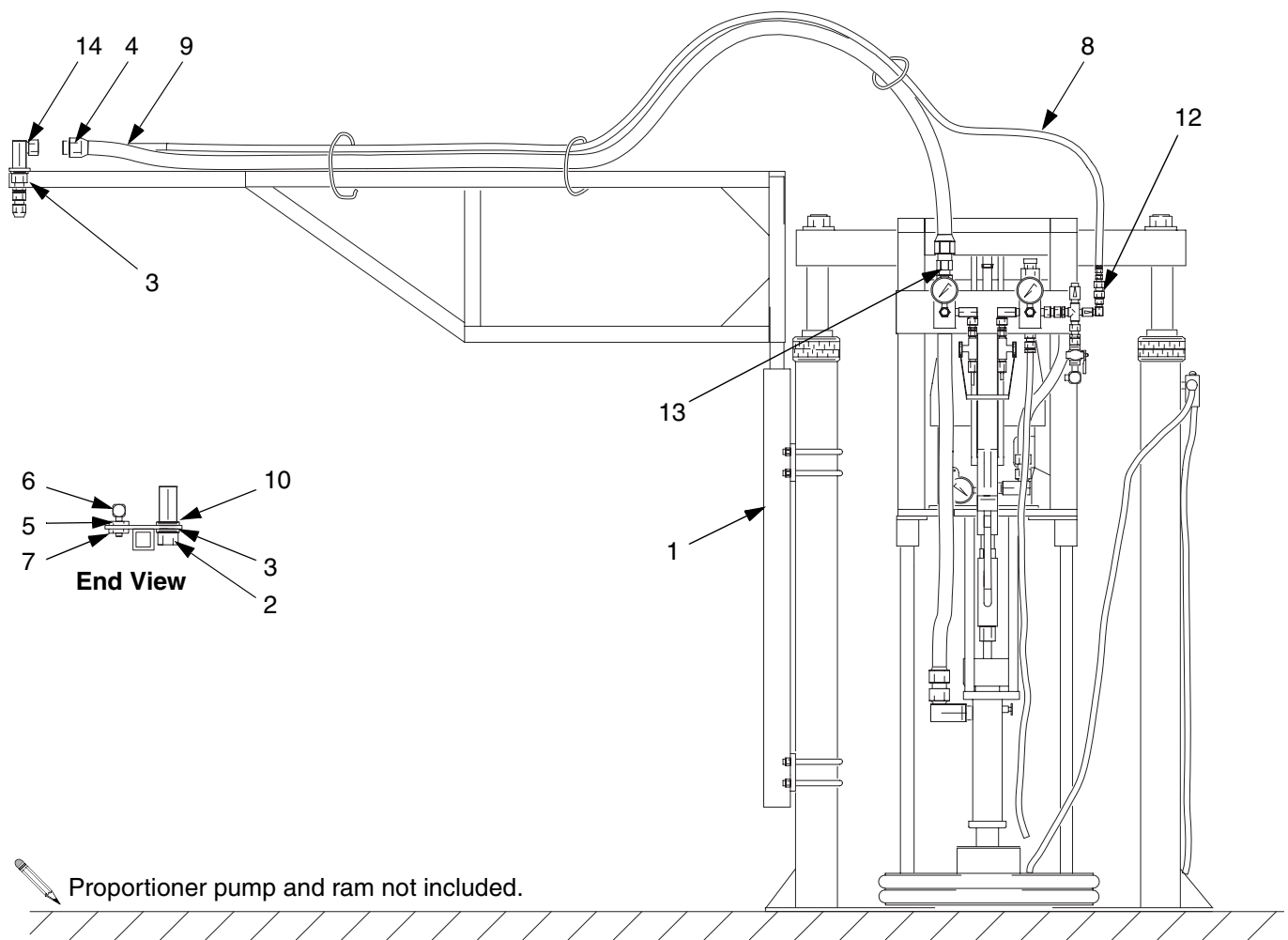

9466A

Part No. 947039

Boom Kit, Configurator Model Option C-1 and C-2

Ref. No.	Part No.	Description	Qty.	Ref. No.	Part No.	Description	Qty.
1	624311	BEARING, boom	1	9	101566	NUT, locking; 3/8-16	2
2	624310	PIPE, boom mount	1	10	105170	SCREW, cap, hex hd; 1/4-20 x 2"	4
3	512555	CLAMP, double	2	11	100015	NUT, hex; 1/4-20	1
4	621674	BEARING, thrust boom	1	12	100016	WASHER, lock; 1/4"	1
5	596828	PIN, roll; 1/4" x 2"	1	13	100086	WASHER; 1/4"	2
6	621677	TUBE, boom mount	1	14	596930	SCREW; 3/8-16 x 2.5"	2
7	947007	FRAME, boom	1	15	100023	WASHER, flat; 3/8"	4
				16	194997	TUBE	1

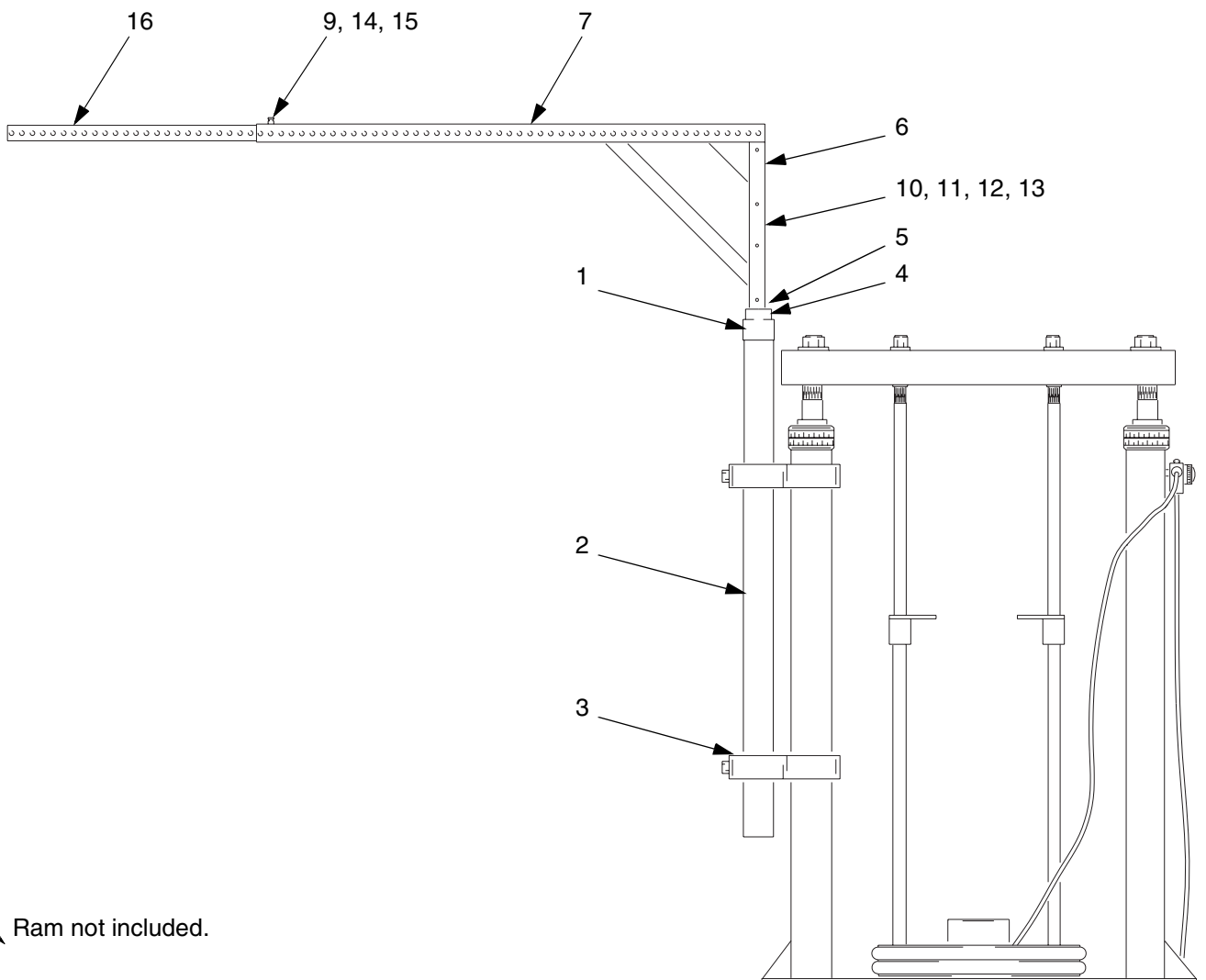

9456A

Part No. 570342

10 ft. Hose Extension Kit, for silicones or urethanes, Configurator Model Option C-3

Ref. No.	Part No.	Description	Qty.
1	202966	UNION; 3/4 npt(f) x 1" npt(f)	1
2	500946	HOSE; 1" ID	1
3	552231	HOSE; PTFE; - 1/4" ID x 12 ft.	1

Part No. 570381

10 ft. Hose Extension Kit, for polysulfides, Configurator Model Option C-4

Ref. No.	Part No.	Description	Qty.
1	202966	UNION; 3/4 npt(f) x 1" npt(f)	1
2	500946	HOSE; 1" ID	1
3	552232	HOSE; PTFE; - 3/8" ID x 12 ft.	1
4	159153	UNION; 3/8 npt(f) x 1/4 npsm(f)	1
5	160022	UNION; 1" npt(m) x 1" npsm(f)	1

Part No. 570292

Resin Purge Flexible Mixer, for polysulfides, Configurator Model Option D-1

Ref. No.	Part No.	Description	Qty.	Ref. No.	Part No.	Description	Qty.
1	512135	NOZZLE	6	12	208434	UNION; 1/8 npt(m) x 1/4 npsm(f)	1
2	235628	VALVE, Ultra-Lite 6000; see manual 308253	1	13	552231	HOSE, catalyst; PTFE; 1/4" x 12 ft.	1
3	514592	ELEMENT, mix	2	14	215441	HOSE, resin; buna-N; 1/2" x 10 ft.	1
4	948097	MIXER, flexible	3	15	157350	NIPPLE; 3/8 npt x 1/4 npt	1
5	501867	VALVE, check; 1/4 npt (mbe)	1	16	156684	UNION; 1/2 npt(m) x 1/2 npsm(f)	2
6	100721	PLUG; 1/4 npt	1	18	512255	RELEASE AGENT, spray can	1
7	207947	SWIVEL, straight; 1/2 npt(m) x 1/2 npsm(f)	1	19	235829	KIT, repair, Ultra-Lite Valve; see manual 308253	1
8	623875	MANIFOLD, mix	1	20	100896	BUSHING; 3/4 npt(m) x 1/2 npt(f)	1
9	552071	SLEEVE, protective; 10 ft.	*	21	624157	HOUSING, injector; 1/4 npt	1
10	151519	NIPPLE; 1/4 npt x 1/8 npt	1	* Order length needed.			
11	512244	VALVE, ball; 1/8 npt (fbe)	1				

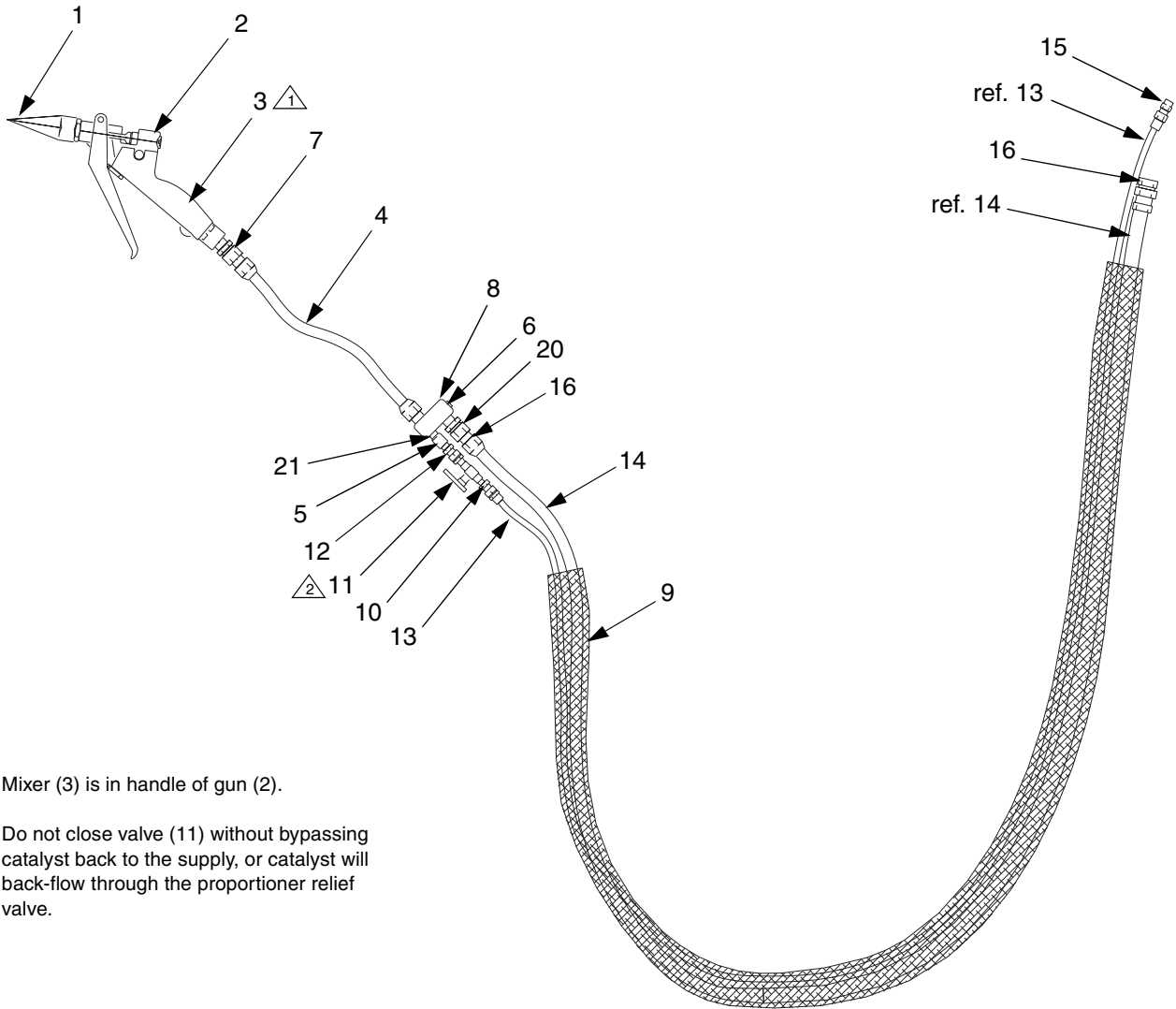

△ Mixer (3) is in handle of gun (2).

△ Do not close valve (11) without bypassing catalyst back to the supply, or catalyst will back-flow through the proportioner relief valve.

Part No. 570294

Resin Purge Flexible Mixer, for silicones, Configurator Model Option D-2

Ref. No.	Part No.	Description	Qty.	Ref. No.	Part No.	Description	Qty.
1	512135	NOZZLE	6	13	552231	HOSE, component B; PTFE; 1/4" x 12 ft.	1
2	235628	VALVE, Ultra-Lite 6000; see manual 308253	1	14	215441	HOSE, resin; buna-N; 1/2" x 10 ft.	1
3	514592	ELEMENT, mix	2	15	157350	NIPPLE; 3/8 npt x 1/4 npt	1
4	948097	MIXER, flexible	3	16	156684	UNION; 1/2 npt(m) x 1/2 npsm(f)	2
5	948258	INJECTOR, #35; 1/4 npt	1	17	512136	TOOL, nut driver; 3/16"; not shown	1
6	100721	PLUG; 1/4 npt	1	18	512255	RELEASE AGENT, spray can	1
7	207947	SWIVEL, straight; 1/2 npt(m) x 1/2 npsm(f)	1	19	235829	KIT, repair, Ultra-Lite Valve; see manual 308253	1
8	623875	MANIFOLD, mix	1	20	100896	BUSHING; 3/4 npt(m) x 1/2 npt(f)	1
9	552071	SLEEVE, protective; 10 ft.	*	21	162453	NIPPLE; 1/4 npt x 1/4 npsm	1
10	151519	NIPPLE; 1/4 npt x 1/8 npt	1	* Order length needed.			
11	512244	VALVE, ball; 1/8 npt (f/b)	1				
12	208434	UNION; 1/8 npt(m) x 1/4 npsm(f)	1				

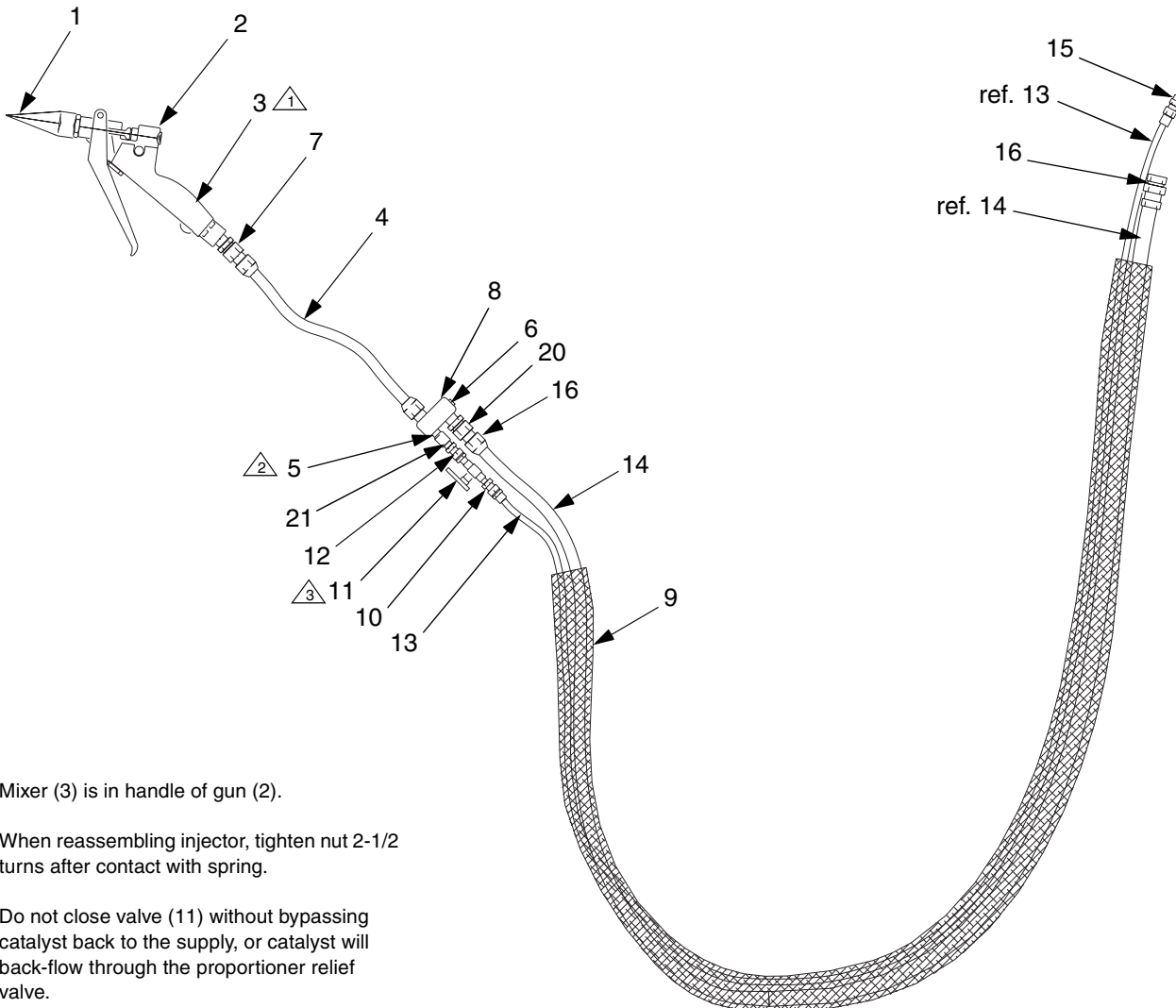

- △1 Mixer (3) is in handle of gun (2).
- △2 When reassembling injector, tighten nut 2-1/2 turns after contact with spring.
- △3 Do not close valve (11) without bypassing catalyst back to the supply, or catalyst will back-flow through the proportioner relief valve.

Part No. 570295

Resin Purge Flexible Mixer, for urethanes, Configurator Model Option D-3

Ref. No.	Part No.	Description	Qty.	Ref. No.	Part No.	Description	Qty.
1	512135	NOZZLE	6	12	208434	UNION; 1/8 npt(m) x 1/4 npsm(f)	1
2	235628	VALVE, Ultra-Lite 6000; see manual 308253	1	13	552231	HOSE, catalyst; PTFE; 1/4" x 12 ft.	1
3	514592	ELEMENT, mix	2	14	215441	HOSE, resin; buna-N; 1/2" x 10 ft.	1
4	948097	MIXER, flexible	3	15	157350	NIPPLE; 3/8 npt x 1/4 npt	1
5	947937	INJECTOR, #40; 1/4 npt	1	16	504520	UNION; 1/2 npt(m) x 3/4 npsm(f)	2
6	100721	PLUG; 1/4 npt	1	17	512136	TOOL, nut driver; 3/16", not shown	1
7	207947	SWIVEL, straight; 1/2 npt(m) x 1/2 npsm(f)	1	18	512255	RELEASE AGENT, spray can	1
8	623875	MANIFOLD, mix	1	19	235829	KIT, repair, Ultra-Lite Valve; see manual 308253	1
9	552071	SLEEVE, protective; 10 ft.	*	20	100896	BUSHING; 3/4 npt(m) x 1/2 npt(f)	1
10	151519	NIPPLE; 1/4 npt x 1/8 npt	1	21	162453	NIPPLE; 1/4 npt x 1/4 npsm	1
11	512244	VALVE, ball; 1/8 npt(fbe)	1	* Order length needed.			

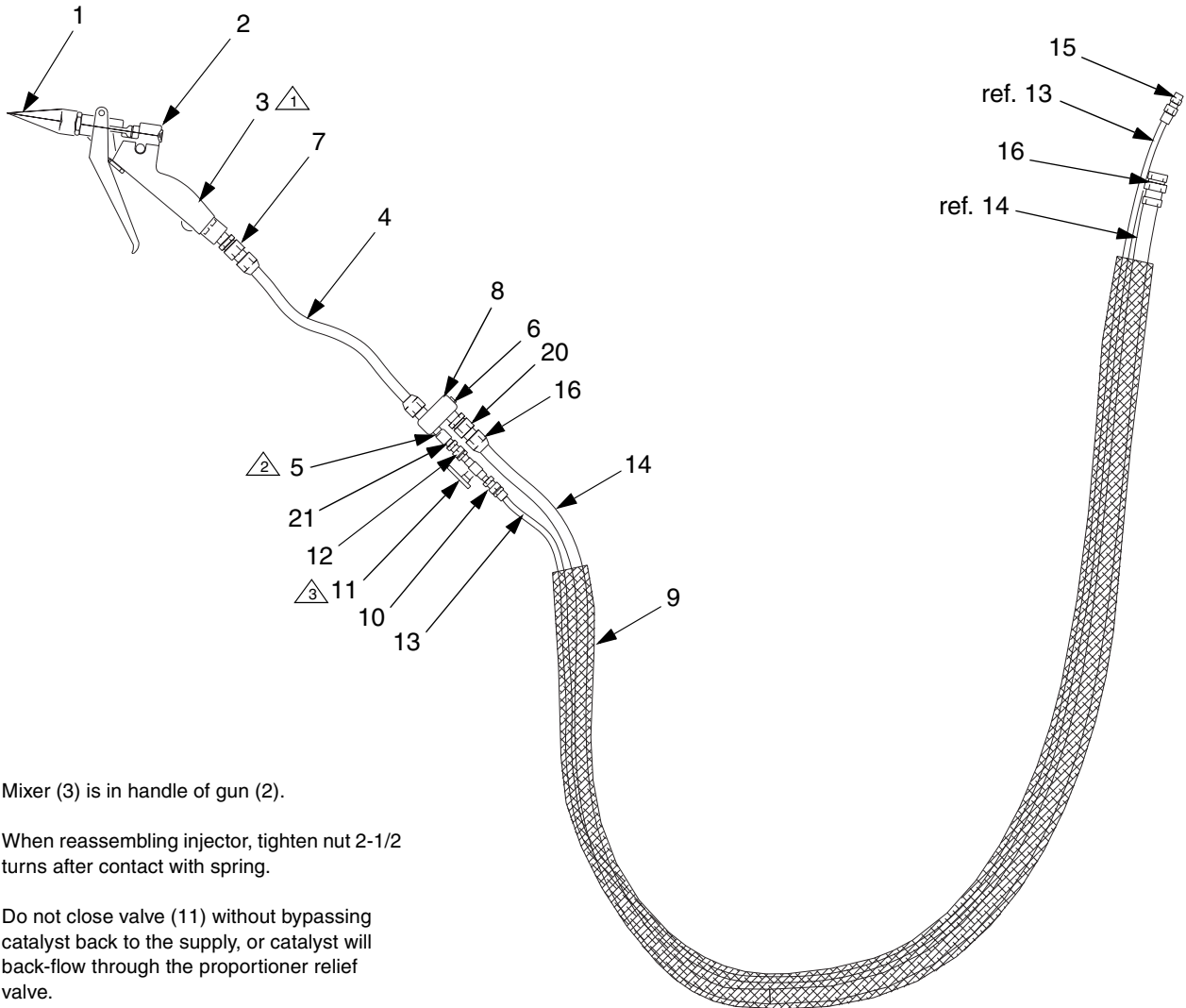

- △ 1 Mixer (3) is in handle of gun (2).
- △ 2 When reassembling injector, tighten nut 2-1/2 turns after contact with spring.
- △ 3 Do not close valve (11) without bypassing catalyst back to the supply, or catalyst will back-flow through the proportioner relief valve.

Part No. 570382

Resin Purge Tri-Core Mixer, for polysulfides, Configurator Model Option D-4

Ref. No.	Part No.	Description	Qty.	Ref. No.	Part No.	Description	Qty.
1	512135	NOZZLE	6	13	552231	HOSE, catalyst; PTFE, 1/4" x 12 ft.	1
2	235628	VALVE, Ultra-Lite 6000; see manual 308253	1	14	215441	HOSE, resin; buna-N; 1/2" x 10 ft.	1
3	514592	ELEMENT, mix	2	15	157350	NIPPLE; 3/8 npt x 1/4 npt	1
4	948259	MIXER, Tri-Core	1	16	156684	UNION; 1/2 npt(m) x 1/2 npsm(f)	2
5	501867	VALVE, check; 1/4 npt (mbe)	1	17	512136	TOOL, nut driver; 3/16"; not shown	1
6	100721	PLUG; 1/4 npt	1	18	512255	RELEASE AGENT, spray can	1
7	207947	SWIVEL, straight; 1/2 npt(m) x 1/2 npsm(f)	1	19	235829	KIT, repair, Ultra-Lite Valve; see manual 308253	1
8	623875	MANIFOLD, mix	1	20	100896	BUSHING; 3/4 npt(m) x 1/2 npt(f)	1
9	552071	SLEEVE, protective; 10 ft.	*	21	624157	HOUSING, injector; 1/4 npt	1
10	151519	NIPPLE; 1/4 npt x 1/8 npt	2	22	512519	ELEMENT, mix; replacement elements for item 4	2
11	512244	VALVE, ball; 1/8 npt(fbe)	1				
12	208434	UNION; 1/8 npt(m) x 1/4 npsm(f)	1				

* Order length needed.

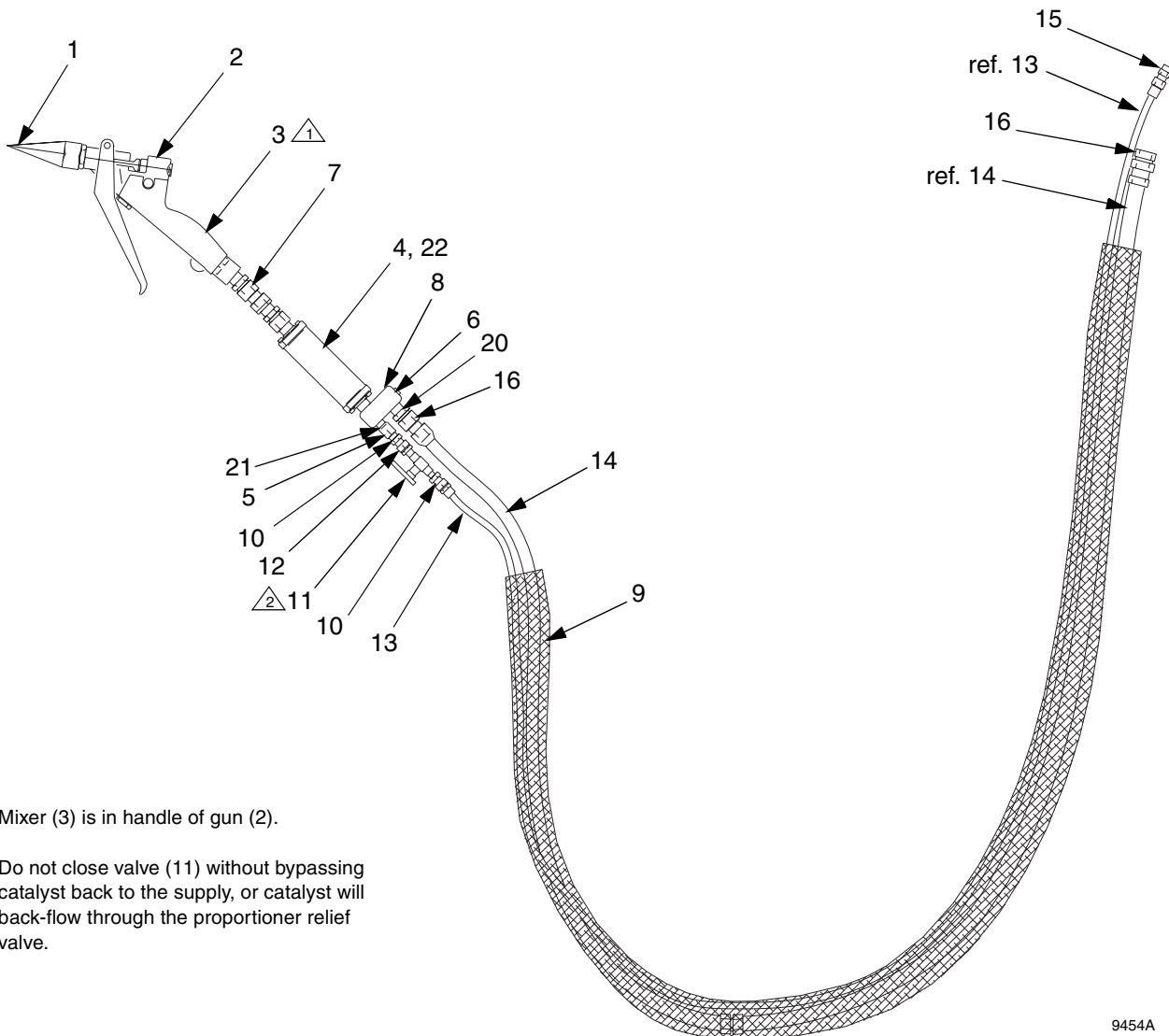

△1 Mixer (3) is in handle of gun (2).

△2 Do not close valve (11) without bypassing catalyst back to the supply, or catalyst will back-flow through the proportioner relief valve.

9454A

Part No. 570383

Resin Purge Tri-Core Mixer, for silicones, Configurator Model Option D-5

Ref. No.	Part No.	Description	Qty.	Ref. No.	Part No.	Description	Qty.
1	512135	NOZZLE	6	13	552231	HOSE, catalyst; PTFE; 1/4" x 12 ft.	1
2	235628	VALVE, Ultra-Lite 6000; see manual 308253	1	14	215441	HOSE, resin; buna-N; 1/2" x 10 ft.	1
3	514592	ELEMENT, mix	2	15	157350	NIPPLE; 3/8 npt x 1/4 npt	1
4	948259	MIXER, Tri-Core	1	16	156684	UNION; 1/2 npt(m) x 1/2 npsm(f)	2
5	948258	INJECTOR, #35; 1/4 npt	1	17	512136	TOOL, nut driver; 3/16"; not shown	1
6	100721	PLUG; 1/4 npt	1	18	512255	RELEASE AGENT, spray can	1
7	207947	SWIVEL, straight; 1/2 npt(m) x 1/2 npsm(f)	1	19	235829	KIT, repair, Ultra-Lite Valve; see manual 308253	1
8	623875	MANIFOLD, mix	1	20	100896	BUSHING; 3/4 npt(m) x 1/2 npt(f)	1
9	552071	SLEEVE, protective; 10 ft.	*	21	162453	NIPPLE; 1/4 npt x 1/4 npsm	1
10	151519	NIPPLE; 1/4 npt x 1/8 npt	1	22	512519	ELEMENT, mix; replacement elements for item 4	1
11	512244	VALVE, ball; 1/8 npt (fbe)	1				
12	208434	UNION; 1/8 npt(m) x 1/4 npsm(f)	1				

* Order length needed.

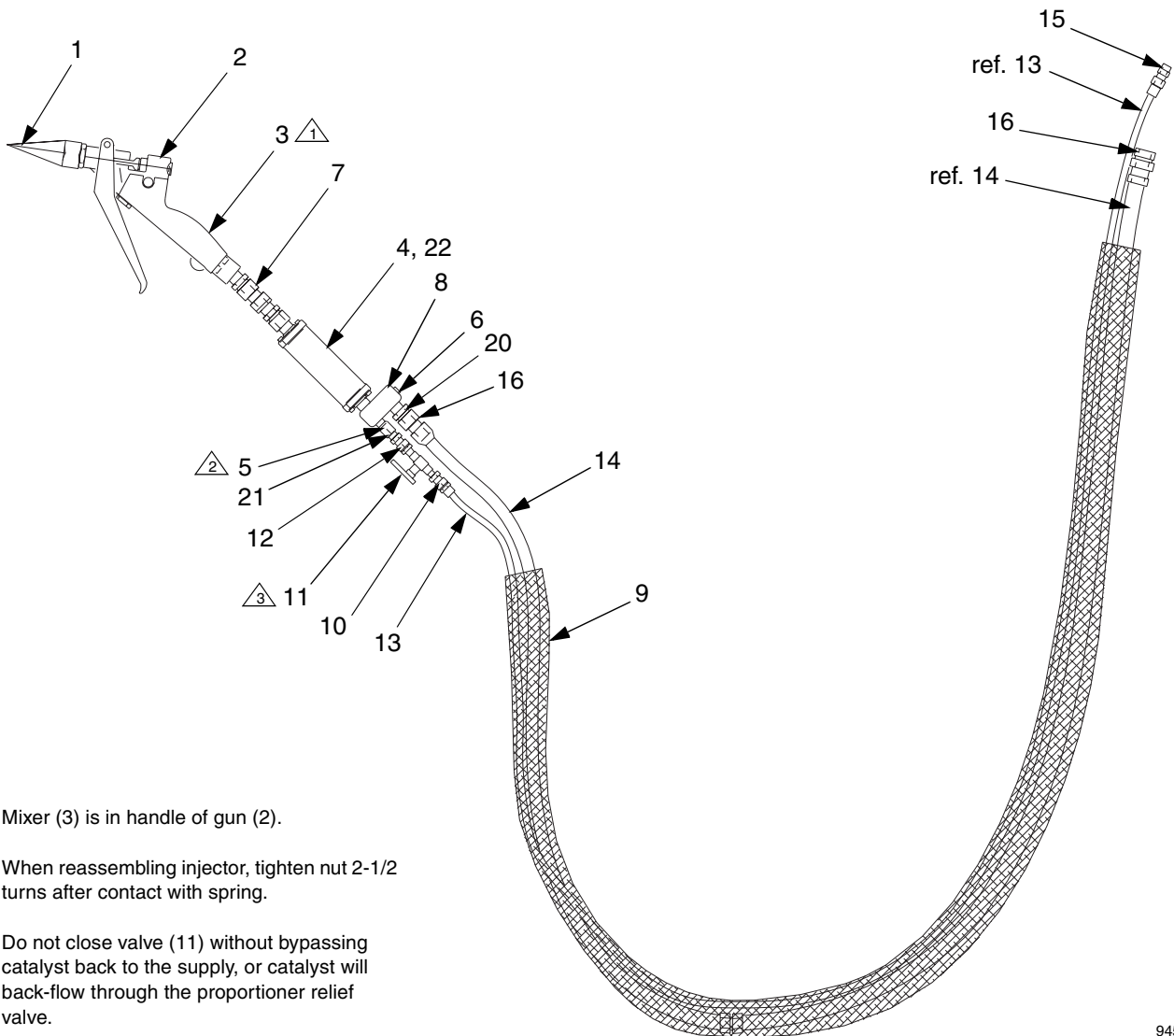

- △1 Mixer (3) is in handle of gun (2).
- △2 When reassembling injector, tighten nut 2-1/2 turns after contact with spring.
- △3 Do not close valve (11) without bypassing catalyst back to the supply, or catalyst will back-flow through the proportioner relief valve.

9455A

Part No. 570384

Resin Purge Tri-Core Mixer, for urethanes, Configurator Model Option D-6

Ref. No.	Part No.	Description	Qty.	Ref. No.	Part No.	Description	Qty.
1	512135	NOZZLE	6	13	552231	HOSE, catalyst; PTFE, 1/4" x 12 ft.	1
2	235628	VALVE, Ultra-Lite 6000; see manual 308253	1	14	215238	HOSE, resin; neoprene; 3/4" x 10 ft.	1
3	514592	ELEMENT, mix	2	15	157350	NIPPLE; 3/8 npt x 1/4 npt	1
4	948259	MIXER, Tri-Core	1	16	504520	UNION; 1/2 npt(m) x 3/4 npsm(f)	2
5	947937	INJECTOR, #40; 1/4 npt	1	17	512136	TOOL, nut driver; 3/16"; not shown	1
6	100721	PLUG; 1/4 npt	1	18	512255	RELEASE AGENT, spray can	1
7	207947	SWIVEL, straight; 1/2 npt(m) x 1/2 npsm(f)	1	19	235829	KIT, repair, Ultra-Lite Valve; see manual 308253	1
8	623875	MANIFOLD, mix	1	20	100896	BUSHING; 3/4 npt(m) x 1/2 npt(f)	1
9	552071	SLEEVE, protective; 10 ft.	*	21	162453	NIPPLE; 1/4 npt x 1/4 npsm	1
10	151519	NIPPLE; 1/4 npt x 1/8 npt	1	22	512519	ELEMENT, mix; replacement elements for item 4	1
11	512244	VALVE, ball; 1/8 npt (f/b)	1				
12	208434	UNION; 1/8 npt(m) x 1/4 npsm(f)	1				

* Order length needed.

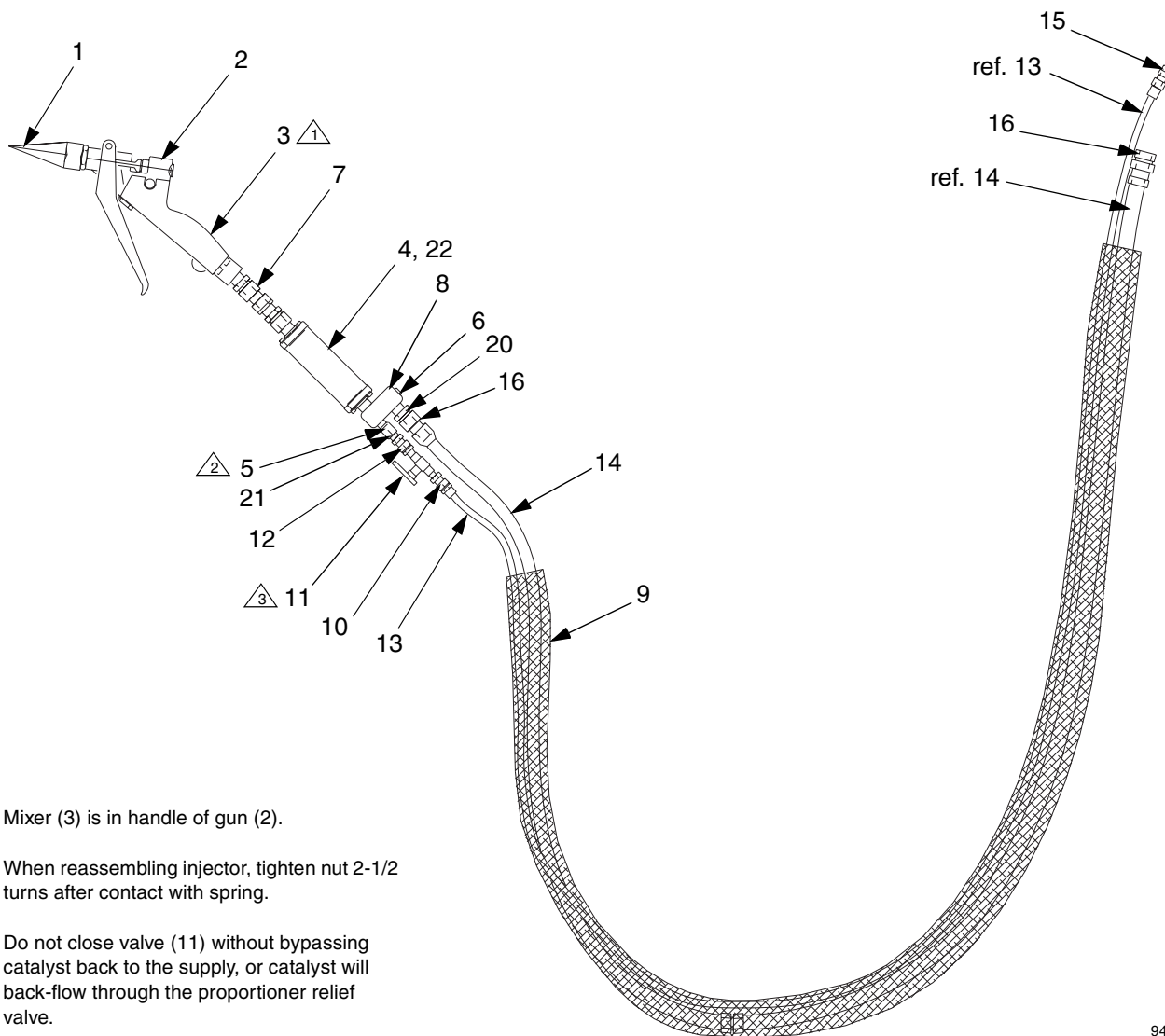

- △1 Mixer (3) is in handle of gun (2).
- △2 When reassembling injector, tighten nut 2-1/2 turns after contact with spring.
- △3 Do not close valve (11) without bypassing catalyst back to the supply, or catalyst will back-flow through the proportioner relief valve.

9455A



A series of horizontal lines spanning the width of the page, providing a template for writing or drawing.

Part No. 570184

2K-UL Disposable Mixer, for polysulfides, Configurator Model Option D-7

Ref. No.	Part No.	Description	Qty.	Ref. No.	Part No.	Description	Qty.
1	155699	ELBOW; 3/8 npt(m x f)	1	19	552071	SLEEVE, protective; 10 ft.	*
2	570182	VALVE, 2K-UL hand gun; see 309000	1	20	514607	TUBE; nylon; 2.5 mm ID; 80 ft.	*
3	157350	NIPPLE; 3/8 x 1/4 npt	1	21	512912	MUFFLER; polyethylene	1
4	100840	ELBOW; 1/4 npt(m x f)	2	23	598327	ELBOW; 5/32" tube x 1/4 npt(m)	2
5	156971	NIPPLE; 1/4 npt	4	24	100615	BUSHING; 3/4 npt(m) x 1/4 npt(f)	1
6	207946	SWIVEL, straight	1	25	104984	TEE; 1/4 npt	2
7	189018	UNION; 1/4 npsm(m x f)	1	26	501459	VALVE, 3-way	1
8	207295	HOSE; PTFE, 13/32" ID x 19"; 3/8 npt(mbe)	1	27	109193	FITTING, tube; 5/32"	2
9	948291	VALVE, injector, #125; 1/4 npt	1	28	150287	COUPLING; 1/4 npt(m) x 3/8 npt(f)	1
10	161490	COUPLING, hex; 3/4 npt x 3/8 npt (fbe)	1	31	593538	VALVE, shuttle; 1/8 npt(f)	1
11	158212	BUSHING; 1/2 npt(m) x 3/8 npt(f)	1	32	103656	NIPPLE; 1/8 npt	1
12	512247	HOSE, resin; PTFE; -5/8" ID x 7.5 ft.; 3/4 npt(mbe)	1	33	104632	VALVE, piloted, 3-way; 1/2"	1
13	552232	HOSE, catalyst; PTFE; 3/8" ID x 12 ft.	1	34	158491	NIPPLE; 1/2 npt	1
14	504520	UNION; 1/2 npt(m) x 3/4 npsm(f)	1	35	551979	MIXER, disposable	10
16	598140	ELBOW; 5/32" tube x 1/8 npt(m)	4	36	512292	NUT, mixer	1
17	155665	UNION, swivel, straight; 3/8 npt(m) x 3/8 npsm(f)	1				
18	155570	SWIVEL; 1/4 npt(m) x 1/4 npsm(f)	1				

* Order length needed.

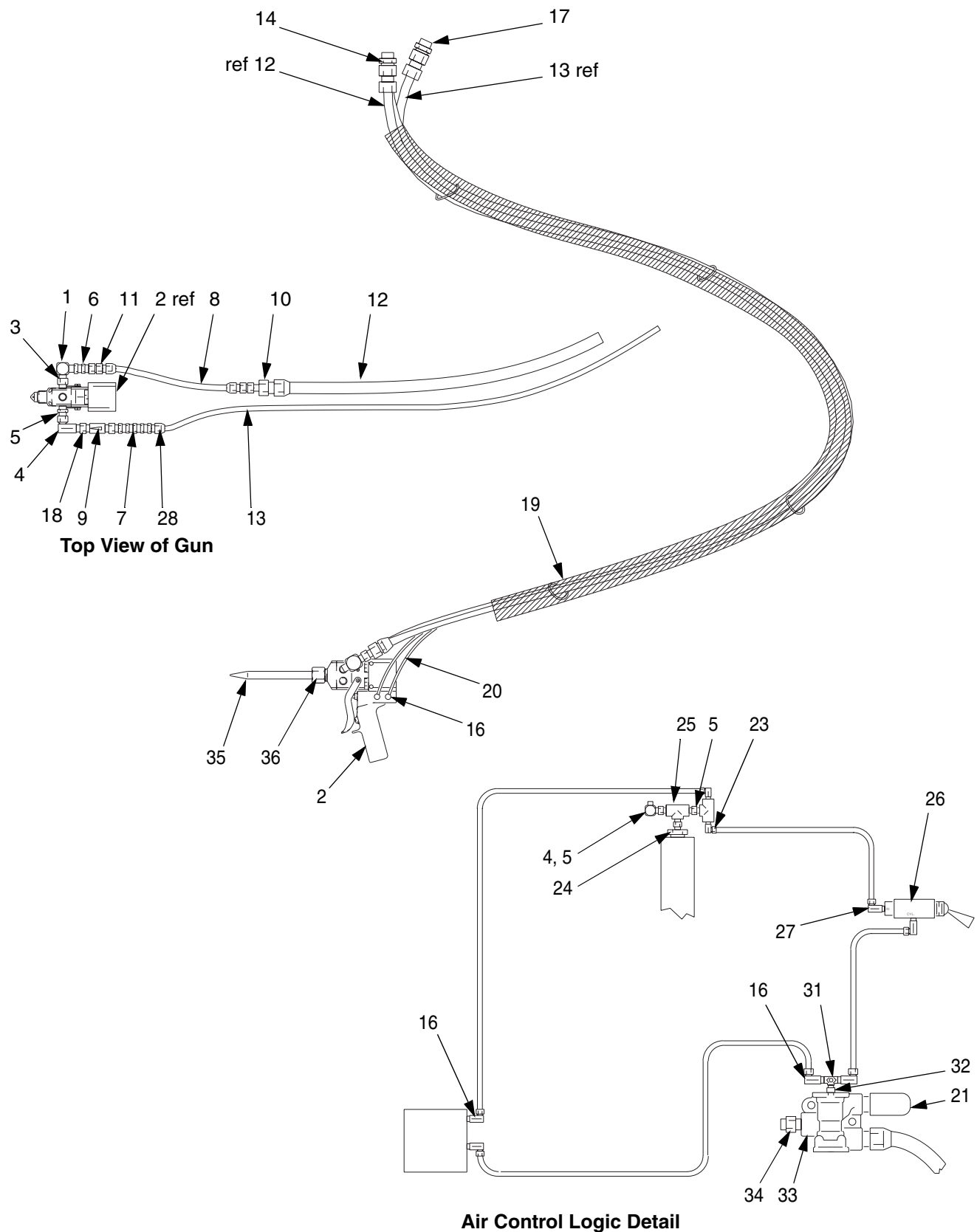

Top View of Gun

Air Control Logic Detail

Part No. 570304

2K-UL Disposable Mixer, for silicones, Configurator Model Option D-8

Ref. No.	Part No.	Description	Qty.	Ref. No.	Part No.	Description	Qty.
1	155699	ELBOW; 3/8 npt(m x f)	1	19	552071	SLEEVE, protective; 10 ft.	*
2	570182	VALVE, 2K-UL hand gun; see 309000	1	20	514607	TUBE; nylon; 2.5 mm ID; 80 ft.	*
3	157350	NIPPLE; 3/8 x 1/4 npt	1	21	512912	MUFFLER; polyethylene	1
4	100840	ELBOW; 1/4 npt (m x f)	1	23	598327	ELBOW; 5/32" tube x 1/4 npt(m)	2
5	156971	NIPPLE; 1/4 npt	4	24	100615	BUSHING; 3/4 npt(m) x 1/4 npt(f)	1
6	207946	SWIVEL, straight	1	25	104984	TEE; 1/4 npt	2
7	189018	UNION; 1/4 npsm(m x f)	1	26	501459	VALVE, 3-way	1
8	207295	HOSE; PTFE; ~13/32" ID x 19"; 3/8 npt(mbe)	1	27	109193	FITTING, tube; 5/32"	2
9	948258	VALVE, injector, #35	1	31	593538	VALVE, shuttle; 1/8 npt(f)	1
10	161490	COUPLING, hex; 3/4 npt x 3/8 npt (fbe)	1	32	103656	NIPPLE; 1/8 npt	1
11	158212	BUSHING; 1/2 npt(m) x 3/8 npt(f)	1	33	104632	VALVE, piloted, 3-way; 1/2"	1
12	512247	HOSE; PTFE; 5/8" ID x 7.5 ft.; 3/4 npt(mbe)	1	34	158491	NIPPLE; 1/2 npt	1
13	552231	HOSE; PTFE; 1/4" ID x 10 ft.; 1/4 npsm(fbe)	2	35	551979	MIXER, disposable	10
14	113344	UNION; 1/2 npt(m) x 3/4 npsm(f)	1	36	512292	NUT, mixer	1
16	598140	ELBOW; 5/32" tube x 1/8 npt(m)	4	* Order length needed.			
17	156823	UNION, swivel, straight; 1/4 npt(m) x 1/4 npsm(f)	1				
18	155570	UNION, swivel; 1/4 npt(fbe)	1				

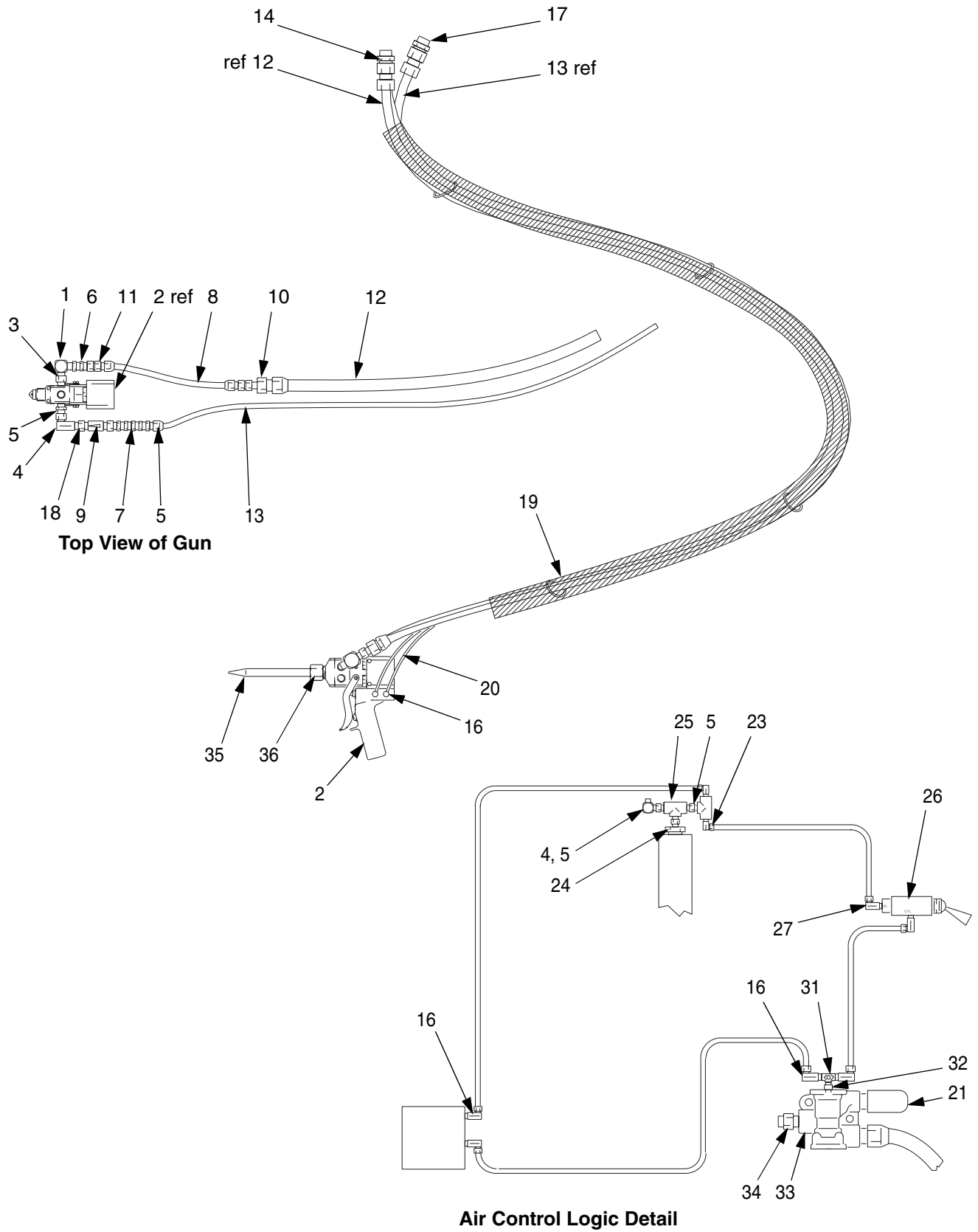

Part No. 570225

2K-UL Disposable Mixer, for urethanes, Configurator Model Option D-9

Ref. No.	Part No.	Description	Qty.	Ref. No.	Part No.	Description	Qty.
1	155699	ELBOW; 3/8 npt(m x f)	1	18	155570	UNION, swivel; 1/4 npt(fbe)	1
2	570182	VALVE, 2K-UL hand gun; see 309000	1	19	552071	SLEEVE, protective; 10 ft.	*
3	157350	NIPPLE; 3/8 x 1/4 npt	2	20	514607	TUBE; nylon; 2.5 mm ID; 80 ft.	*
4	100840	ELBOW; 1/4 npt (m x f)	2	21	512912	MUFFLER; polyethylene	1
5	156971	NIPPLE; 1/4 npt	5	23	598327	ELBOW; 5/32" tube x 1/4 npt(m)	2
6	207946	SWIVEL, straight	1	24	100615	BUSHING; 3/4 npt(m) x 1/4 npt(f)	1
7	189018	UNION; 1/4 npsm(m x f)	1	25	104984	TEE; 1/4 npt	2
8	207295	HOSE; PTFE; 13/32" ID x 19"; 3/8 npt(mbe)	1	26	501459	VALVE, 3-way	1
9	570251	VALVE, injector, #42	1	27	109193	FITTING, tube; 5/32"	2
10	161490	COUPLING, hex; 3/4 npt x 3/8 npt (fbe)	1	31	593538	VALVE, shuttle; 1/8 npt(f)	1
11	158212	BUSHING; 1/2 npt(m) x 3/8 npt(f)	1	32	103656	NIPPLE; 1/8 npt	1
12	512247	HOSE; PTFE; 5/8" ID x 7.5 ft.; 3/4 npt(mbe)	1	33	104632	VALVE, piloted, 3-way; 1/2"	1
13	552231	HOSE; PTFE; 1/4" ID x 10 ft.; 1/4 npsm(fbe)	1	34	158491	NIPPLE; 1/2 npt	1
14	113344	UNION; 1/2 npt(m) x 3/4 npsm(f)	1	35	551979	MIXER, disposable	10
16	598140	ELBOW; 5/32" tube x 1/8 npt(m)	4	36	512292	NUT, mixer	1
				*	<i>Order length needed.</i>		

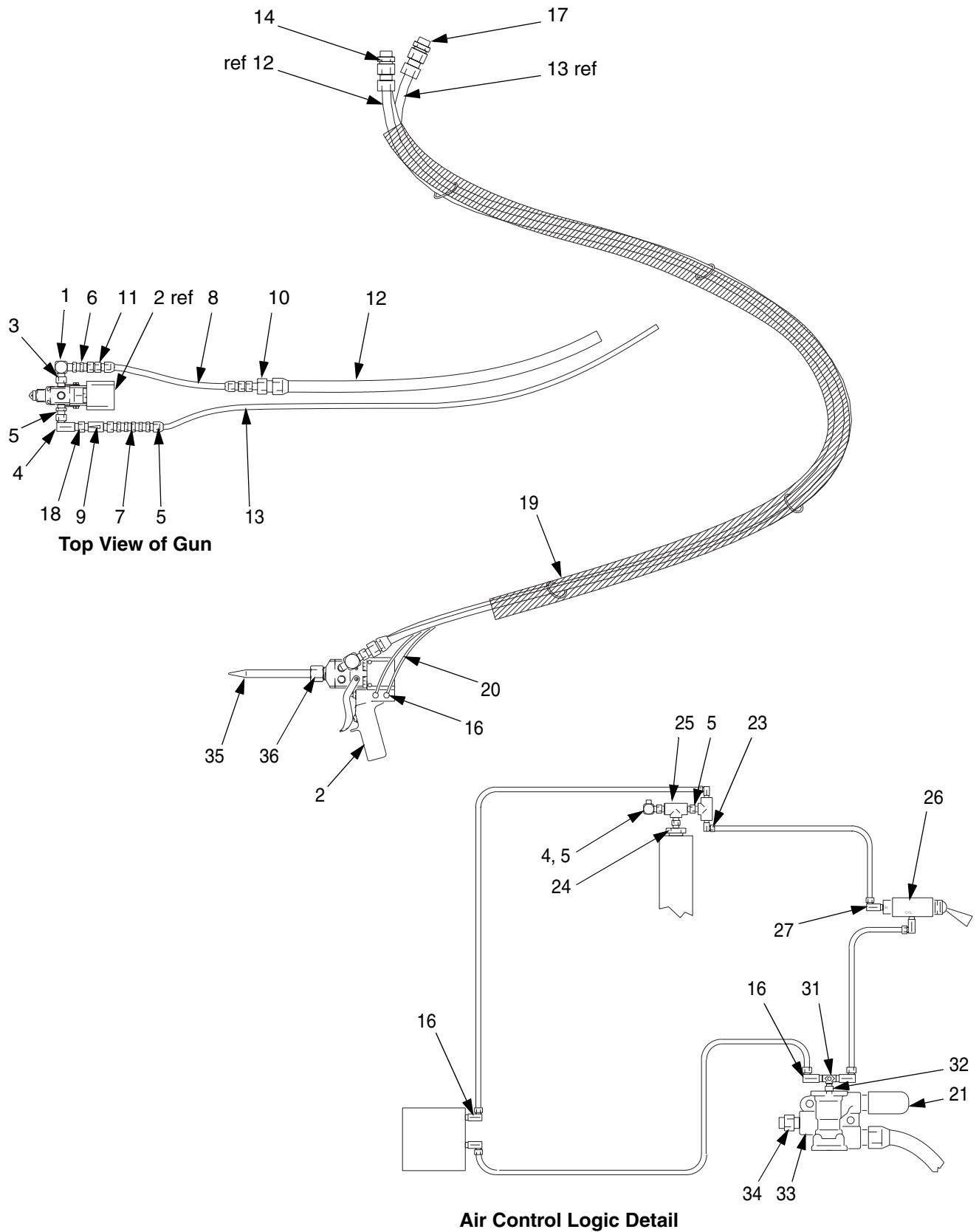

9457A

Part No. 233415

Ratio Restriction Check Kit, Configurator Model Option E-1
See manual 309207 for parts list and instructions.

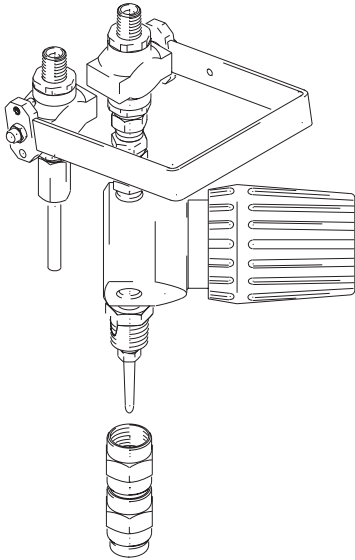

Accessories

Part No. 551327

Disposable outlet cap for 2K UltraLite valve.

Part No. 111329

Polyethylene liner for 5 gallon catalyst tank.

Part No. 106498

Desiccant refill, 1 qt. jar

Part No. 686604

Piston packing kit - solid piston packing for use with resin materials which experience piston binding with v-packings

Technical Data

- Maximum system working pressure 3000 psi (21 MPa, 207 bar)
- Maximum air motor input pressure 100 psi (0.7 MPa, 7 bar)
- Air inlet size 3/4 npsm(f)
- Pump fluid outlet size
 - Slave Pump 3/8 npt(f)
 - Master Pump 1" npt(f)



- Refer to pump Output Charts on pages 13-16 for ratio adjustment and displacement pump part no. information.
- For wetted parts information and additional technical data, refer to your separate component manuals.

Sound Pressure Levels (dBa) (measured at 1 meter from unit)

Air Motor	Input Air Pressures at 15 cycles per minute			
	40 psi (0.28 MPa, 2.8 bar)	70 psi (0.48 MPa, 4.8 bar)	90 psi (0.6 MPa, 6.2 bar)	100 psi (0.7 MPa, 7 bar)
Bulldog	82.4	87.3	88.5	90.0
Quiet King	77.9	79.2	87.5	n/a

Sound Power Levels (dBa) (tested in accordance with ISO 9614-2)

Air Motor	Input Air Pressures at 15 cycles per minute			
	40 psi (0.28 MPa, 2.8 bar)	70 psi (0.48 MPa, 4.8 bar)	90 psi (0.6 MPa, 6.2 bar)	100 psi (0.7 MPa, 7 bar)
Bulldog	91.6	95.9	97.4	98.1
Quiet King	85.2	86.6	95.2	n/a

Graco Warranty

Graco warrants all equipment referenced in this document which is manufactured by Graco and bearing its name to be free from defects in material and workmanship on the date of sale by an authorized Graco distributor to the original purchaser for use. With the exception of any special, extended, or limited warranty published by Graco, Graco will, for a period of twelve months from the date of sale, repair or replace any part of the equipment determined by Graco to be defective. This warranty applies only when the equipment is installed, operated and maintained in accordance with Graco's written recommendations.

Graco warrants all equipment referenced in this document which is manufactured by Graco and bearing its name to be free from defects in material and workmanship on the date of sale by an authorized Graco distributor to the original purchaser for use. With the exception of any special, extended, or limited warranty published by Graco, Graco will, for a period of twelve months from the date of sale, repair or replace any part of the equipment determined by Graco to be defective. This warranty applies only when the equipment is installed, operated and maintained in accordance with Graco's written recommendations.

This warranty does not cover, and Graco shall not be liable for general wear and tear, or any malfunction, damage or wear caused by faulty installation, misapplication, abrasion, corrosion, inadequate or improper maintenance, negligence, accident, tampering, or substitution of non-Graco component parts. Nor shall Graco be liable for malfunction, damage or wear caused by the incompatibility of Graco equipment with structures, accessories, equipment or materials not supplied by Graco, or the improper design, manufacture, installation, operation or maintenance of structures, accessories, equipment or materials not supplied by Graco.

This warranty is conditioned upon the prepaid return of the equipment claimed to be defective to an authorized Graco distributor for verification of the claimed defect. If the claimed defect is verified, Graco will repair or replace free of charge any defective parts. The equipment will be returned to the original purchaser transportation prepaid. If inspection of the equipment does not disclose any defect in material or workmanship, repairs will be made at a reasonable charge, which charges may include the costs of parts, labor, and transportation.

THIS WARRANTY IS EXCLUSIVE, AND IS IN LIEU OF ANY OTHER WARRANTIES, EXPRESS OR IMPLIED, INCLUDING BUT NOT LIMITED TO WARRANTY OF MERCHANTABILITY OR WARRANTY OF FITNESS FOR A PARTICULAR PURPOSE.

Graco's sole obligation and buyer's sole remedy for any breach of warranty shall be as set forth above. The buyer agrees that no other remedy (including, but not limited to, incidental or consequential damages for lost profits, lost sales, injury to person or property, or any other incidental or consequential loss) shall be available. Any action for breach of warranty must be brought within two (2) years of the date of sale.

GRACO MAKES NO WARRANTY, AND DISCLAIMS ALL IMPLIED WARRANTIES OF MERCHANTABILITY AND FITNESS FOR A PARTICULAR PURPOSE, IN CONNECTION WITH ACCESSORIES, EQUIPMENT, MATERIALS OR COMPONENTS SOLD BUT NOT MANUFACTURED BY GRACO. These items sold, but not manufactured by Graco (such as electric motors, switches, hose, etc.), are subject to the warranty, if any, of their manufacturer. Graco will provide purchaser with reasonable assistance in making any claim for breach of these warranties.

In no event will Graco be liable for indirect, incidental, special or consequential damages resulting from Graco supplying equipment hereunder, or the furnishing, performance, or use of any products or other goods sold hereto, whether due to a breach of contract, breach of warranty, the negligence of Graco, or otherwise.

FOR GRACO CANADA CUSTOMERS

The Parties acknowledge that they have required that the present document, as well as all documents, notices and legal proceedings entered into, given or instituted pursuant hereto or relating directly or indirectly hereto, be drawn up in English. Les parties reconnaissent avoir convenu que la rédaction du présente document sera en Anglais, ainsi que tous documents, avis et procédures judiciaires exécutés, donnés ou intentés, à la suite de ou en rapport, directement ou indirectement, avec les procédures concernées.

Graco Phone Number

TO PLACE AN ORDER, contact your Graco distributor or call to identify the nearest distributor:

Phone: 612-623-6921 **or Toll Free:** 1-800-367-4023, **Fax:** 612-378-3505

*All written and visual data contained in this document reflects the latest product information available at the time of publication.
Graco reserves the right to make changes at any time without notice.*

Sales Offices: Minneapolis, Detroit
International Offices: Belgium Korea, Hong Kong, Japan
GRACO INC. P.O. BOX 1441 MINNEAPOLIS, MN 55440-1441
www.graco.com
Printed in USA 308930A